

## 2.2 Main Body

### 2.2.1 Outside of the main body (front)

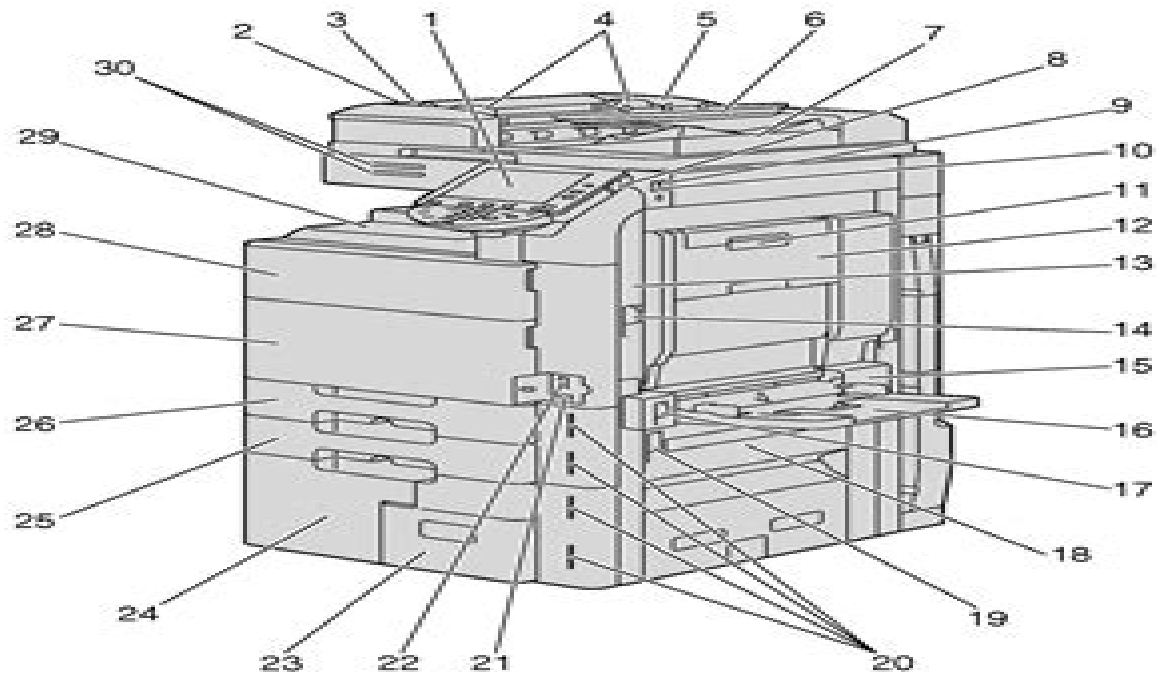

No.	Name
1	Control panel
2	Left-side cover release lever
3	Left-side cover
4	Lateral guide
5	ADF
6	Original tray
7	Original output tray
8	Sub power switch
9	USB port (type A) USB 2.0/1.1
10	USB port (type A) USB 2.0/1.1 (For compact keyboard)
11	Automatic duplex unit release lever
12	Automatic duplex unit

# Parts Guide Manual Bizhub C452 A0p

**Roman Wölfel**



**Parts Guide Manual Bizhub C452 A0p:**

*Chilton's Labor Guide and Parts Manual* Chilton Book Company,1974      *Chilton's Labor Guide and Parts Manual* ,1974

**Chilton's Nineteen Eighty-One Labor Guide and Parts Manual** Chilton Automotive Books,1981-01-01

Professional Labor Guide and Parts Manual 1965-1973 Chilton Book Company,1982-03-01

Ignite the flame of optimism with *Crafted* by is motivational masterpiece, Find Positivity in **Parts Guide Manual Bizhub C452 A0p** . In a downloadable PDF format ( PDF Size: \*), this ebook is a beacon of encouragement. Download now and let the words propel you towards a brighter, more motivated tomorrow.

[https://correiodobrasil.blogosfero.cc/data/scholarship/Download\\_PDFS/parcc%20assessment%20questions%20from%20the%20watsons%20go%20to%20birmingham.pdf](https://correiodobrasil.blogosfero.cc/data/scholarship/Download_PDFS/parcc%20assessment%20questions%20from%20the%20watsons%20go%20to%20birmingham.pdf)

## **Table of Contents Parts Guide Manual Bizhub C452 A0p**

1. Understanding the eBook Parts Guide Manual Bizhub C452 A0p
  - The Rise of Digital Reading Parts Guide Manual Bizhub C452 A0p
  - Advantages of eBooks Over Traditional Books
2. Identifying Parts Guide Manual Bizhub C452 A0p
  - Exploring Different Genres
  - Considering Fiction vs. Non-Fiction
  - Determining Your Reading Goals
3. Choosing the Right eBook Platform
  - Popular eBook Platforms
  - Features to Look for in an Parts Guide Manual Bizhub C452 A0p
  - User-Friendly Interface
4. Exploring eBook Recommendations from Parts Guide Manual Bizhub C452 A0p
  - Personalized Recommendations
  - Parts Guide Manual Bizhub C452 A0p User Reviews and Ratings
  - Parts Guide Manual Bizhub C452 A0p and Bestseller Lists
5. Accessing Parts Guide Manual Bizhub C452 A0p Free and Paid eBooks
  - Parts Guide Manual Bizhub C452 A0p Public Domain eBooks
  - Parts Guide Manual Bizhub C452 A0p eBook Subscription Services
  - Parts Guide Manual Bizhub C452 A0p Budget-Friendly Options

6. Navigating Parts Guide Manual Bizhub C452 A0p eBook Formats
  - ePub, PDF, MOBI, and More
  - Parts Guide Manual Bizhub C452 A0p Compatibility with Devices
  - Parts Guide Manual Bizhub C452 A0p Enhanced eBook Features
7. Enhancing Your Reading Experience
  - Adjustable Fonts and Text Sizes of Parts Guide Manual Bizhub C452 A0p
  - Highlighting and Note-Taking Parts Guide Manual Bizhub C452 A0p
  - Interactive Elements Parts Guide Manual Bizhub C452 A0p
8. Staying Engaged with Parts Guide Manual Bizhub C452 A0p
  - Joining Online Reading Communities
  - Participating in Virtual Book Clubs
  - Following Authors and Publishers Parts Guide Manual Bizhub C452 A0p
9. Balancing eBooks and Physical Books Parts Guide Manual Bizhub C452 A0p
  - Benefits of a Digital Library
  - Creating a Diverse Reading Collection Parts Guide Manual Bizhub C452 A0p
10. Overcoming Reading Challenges
  - Dealing with Digital Eye Strain
  - Minimizing Distractions
  - Managing Screen Time
11. Cultivating a Reading Routine Parts Guide Manual Bizhub C452 A0p
  - Setting Reading Goals Parts Guide Manual Bizhub C452 A0p
  - Carving Out Dedicated Reading Time
12. Sourcing Reliable Information of Parts Guide Manual Bizhub C452 A0p
  - Fact-Checking eBook Content of Parts Guide Manual Bizhub C452 A0p
  - Distinguishing Credible Sources
13. Promoting Lifelong Learning
  - Utilizing eBooks for Skill Development
  - Exploring Educational eBooks
14. Embracing eBook Trends
  - Integration of Multimedia Elements

- Interactive and Gamified eBooks

## **Parts Guide Manual Bizhub C452 A0p Introduction**

Free PDF Books and Manuals for Download: Unlocking Knowledge at Your Fingertips In today's fast-paced digital age, obtaining valuable knowledge has become easier than ever. Thanks to the internet, a vast array of books and manuals are now available for free download in PDF format. Whether you are a student, professional, or simply an avid reader, this treasure trove of downloadable resources offers a wealth of information, conveniently accessible anytime, anywhere. The advent of online libraries and platforms dedicated to sharing knowledge has revolutionized the way we consume information. No longer confined to physical libraries or bookstores, readers can now access an extensive collection of digital books and manuals with just a few clicks. These resources, available in PDF, Microsoft Word, and PowerPoint formats, cater to a wide range of interests, including literature, technology, science, history, and much more. One notable platform where you can explore and download free Parts Guide Manual Bizhub C452 A0p PDF books and manuals is the internet's largest free library. Hosted online, this catalog compiles a vast assortment of documents, making it a veritable goldmine of knowledge. With its easy-to-use website interface and customizable PDF generator, this platform offers a user-friendly experience, allowing individuals to effortlessly navigate and access the information they seek. The availability of free PDF books and manuals on this platform demonstrates its commitment to democratizing education and empowering individuals with the tools needed to succeed in their chosen fields. It allows anyone, regardless of their background or financial limitations, to expand their horizons and gain insights from experts in various disciplines. One of the most significant advantages of downloading PDF books and manuals lies in their portability. Unlike physical copies, digital books can be stored and carried on a single device, such as a tablet or smartphone, saving valuable space and weight. This convenience makes it possible for readers to have their entire library at their fingertips, whether they are commuting, traveling, or simply enjoying a lazy afternoon at home. Additionally, digital files are easily searchable, enabling readers to locate specific information within seconds. With a few keystrokes, users can search for keywords, topics, or phrases, making research and finding relevant information a breeze. This efficiency saves time and effort, streamlining the learning process and allowing individuals to focus on extracting the information they need. Furthermore, the availability of free PDF books and manuals fosters a culture of continuous learning. By removing financial barriers, more people can access educational resources and pursue lifelong learning, contributing to personal growth and professional development. This democratization of knowledge promotes intellectual curiosity and empowers individuals to become lifelong learners, promoting progress and innovation in various fields. It is worth noting that while accessing free Parts Guide Manual Bizhub C452 A0p PDF books and manuals is convenient and cost-effective, it is vital to respect copyright laws and intellectual property rights. Platforms offering free downloads often operate within legal

boundaries, ensuring that the materials they provide are either in the public domain or authorized for distribution. By adhering to copyright laws, users can enjoy the benefits of free access to knowledge while supporting the authors and publishers who make these resources available. In conclusion, the availability of Parts Guide Manual Bizhub C452 A0p free PDF books and manuals for download has revolutionized the way we access and consume knowledge. With just a few clicks, individuals can explore a vast collection of resources across different disciplines, all free of charge. This accessibility empowers individuals to become lifelong learners, contributing to personal growth, professional development, and the advancement of society as a whole. So why not unlock a world of knowledge today? Start exploring the vast sea of free PDF books and manuals waiting to be discovered right at your fingertips.

### **FAQs About Parts Guide Manual Bizhub C452 A0p Books**

**What is a Parts Guide Manual Bizhub C452 A0p PDF?** A PDF (Portable Document Format) is a file format developed by Adobe that preserves the layout and formatting of a document, regardless of the software, hardware, or operating system used to view or print it. **How do I create a Parts Guide Manual Bizhub C452 A0p PDF?** There are several ways to create a PDF: Use software like Adobe Acrobat, Microsoft Word, or Google Docs, which often have built-in PDF creation tools. Print to PDF: Many applications and operating systems have a "Print to PDF" option that allows you to save a document as a PDF file instead of printing it on paper. Online converters: There are various online tools that can convert different file types to PDF. **How do I edit a Parts Guide Manual Bizhub C452 A0p PDF?** Editing a PDF can be done with software like Adobe Acrobat, which allows direct editing of text, images, and other elements within the PDF. Some free tools, like PDFescape or Smallpdf, also offer basic editing capabilities. **How do I convert a Parts Guide Manual Bizhub C452 A0p PDF to another file format?** There are multiple ways to convert a PDF to another format: Use online converters like Smallpdf, Zamzar, or Adobe Acrobat's export feature to convert PDFs to formats like Word, Excel, JPEG, etc. Software like Adobe Acrobat, Microsoft Word, or other PDF editors may have options to export or save PDFs in different formats. **How do I password-protect a Parts Guide Manual Bizhub C452 A0p PDF?** Most PDF editing software allows you to add password protection. In Adobe Acrobat, for instance, you can go to "File" -> "Properties" -> "Security" to set a password to restrict access or editing capabilities. Are there any free alternatives to Adobe Acrobat for working with PDFs? Yes, there are many free alternatives for working with PDFs, such as: LibreOffice: Offers PDF editing features. PDFsam: Allows splitting, merging, and editing PDFs. Foxit Reader: Provides basic PDF viewing and editing capabilities. How do I compress a PDF file? You can use online tools like Smallpdf, ILovePDF, or desktop software like Adobe Acrobat to compress PDF files without significant quality loss. Compression reduces the file size, making it easier to share and download. Can I fill out forms in a

PDF file? Yes, most PDF viewers/editors like Adobe Acrobat, Preview (on Mac), or various online tools allow you to fill out forms in PDF files by selecting text fields and entering information. Are there any restrictions when working with PDFs? Some PDFs might have restrictions set by their creator, such as password protection, editing restrictions, or print restrictions. Breaking these restrictions might require specific software or tools, which may or may not be legal depending on the circumstances and local laws.

**Find Parts Guide Manual Bizhub C452 A0p :**

[parcc assessment questions from the watsons go to birmingham](#)

**paramedic manual**

[papier global internationale papierkunst triennale](#)

[panasonic vcr repair manual](#)

[parsons bookshop at the heart of bohemian dublin 1948 89 paperback common](#)

**panorama 4th edition supersite answers leccion 8**

**partition wizard user manual**

**parrot minikit nomad manual**

[part design in autocad inventor 2015 manuals](#)

**papillon 2016 calendrier mural france**

[panasonic th 50bt300u plasma tv service manual](#)

**parents guide to confirmation**

**panasonic tv service manuals free**

[panasonic th 42pa50 plasma television service manual](#)

[paris fashion a cultural history](#)

**Parts Guide Manual Bizhub C452 A0p :**

**dossier de prensa fotografía inteligente con lightroom 5** - Aug 03 2022

web nov 6 2013 dossier de prensa fotografía inteligente con lightroom 5 de josé maría mellado anaya multimedia photoclub

**fotografía inteligente con lightroom 5 photoclub tapa blanda** - Feb 09 2023

web fotografía inteligente con lightroom 5 photoclub de mellado josé maría en iberlibro com isbn 10 8441535159 isbn 13

9788441535152 grupo anaya publicaciones generales 2013 tapa blanda fotografía inteligente con lightroom 5 photoclub



mellado josé maría 9788441535152 iberlibro

**9788441535152 fotografía inteligente con lightroom 5 photoclub** - Mar 10 2023

web fotografía inteligente con lightroom 5 photoclub encuentre todos los libros de mellado josé maría con terralibro com usted puede comprar libros antiguos nuevos y usados inmediatamente y pedirlos al mejor precio 9788441535152 mucho más que un manual este libro es una guía de cómo conseguir que

**fotografía inteligente con lightroom 5 photoclub zva** - May 12 2023

web fotografía inteligente con lightroom 5 photoclub von mellado josé maría beim zva com isbn 10 8441535159 isbn 13 9788441535152 grupo anaya publicaciones generales 2013 softcover

descargarfotografía inteligente con lightroom 5 photoclub - Dec 27 2021

web may 27 2021 puedes leer el fotografía inteligente con lightroom 5 photoclub en línea con pasos sencillos pero si quieres guardarlo en tu computadora ahora puedes descargar fotografía inteligente con lightroom 5 photoclub

*fotografía inteligente con lightroom 5 photoclub softcover* - Dec 07 2022

web fotografía inteligente con lightroom 5 photoclub von mellado josé maría bei abebooks de isbn 10 8441535159 isbn 13 9788441535152 grupo anaya publicaciones generales 2013 softcover

fotografía inteligente con lightroom 5 photoclub tapa blanda - Aug 15 2023

web compra verificada jose maría mellado es uno de los más conocidos en el mundo de la fotografía en el libro describe de manera clara y paso a paso cómo ir conociendo y controlando todas las opciones que brinda lightroom 5 desde la importación de las fotografías hasta el revelado final pasando por el tratamiento

**fotografía inteligente con lightroom 5 photoclub nice slideshare** - Feb 26 2022

web detail book title fotografía inteligente con lightroom 5 photoclub format pdf kindle epub language english asin 8 441535159e9 paperback 282 pages pr

**fotografía inteligente con lightroom 5 photoclub taschenbuch amazon de** - Apr 11 2023

web fotografía inteligente con lightroom 5 photoclub mellado josé maría amazon de bücher

**libro fotografía inteligente con lightroom 5 photoclub de** - Jan 28 2022

web may 7 2021 name fotografía inteligente con lightroom 5 photoclub autor josé maría mellado categoria libros arte cine y fotografía fotografía tamaño del archivo 9 mb tipos de archivo pdf document idioma español archivos de estado available descargar ebook fotografía inteligente con lightroom 5 photoclub de josé maría

**fotografía inteligente con lightroom 5 photoclub pdf epub** - Apr 30 2022

web isbn 7536576803974 kategorie book you might copy this ebook i equip downloads as a pdf amazondx word txt ppt rar and zip there are many books in the world that can improve our knowledge one of them is the book entitled fotografía

inteligente con lightroom 5 photoclub by José María Mellado

recomendación literaria fotografía inteligente con lightroom 5 - Jul 14 2023

web composición y diseño de fotografía inteligente con lightroom 5 el libro se organiza en 6 temas diferentes con sus correspondientes subtemas veamos de qué trata cada uno de ellos tema 1 arrancando en este tema verás todo lo necesario para entender lightroom desde el principio

fotografía inteligente con lightroom 5 casa del libro - Nov 06 2022

web sinopsis de fotografía inteligente con lightroom 5 mucho más que un manual este libro es una guía de cómo conseguir que manejar miles de imágenes se convierta en una labor eficiente sencilla y gratificante mediante adobe lightroom y empleando los métodos y técnicas más depurados resultado de años de experiencia

fotografía inteligente con lightroom 5 spanish edition - Mar 30 2022

web abebooks com fotografía inteligente con lightroom 5 spanish edition 9788441535152 by mellado José María and a great selection of similar new used and collectible books available now at great prices

**fotografía inteligente con lightroom 5 photoclub paperback amazon de** - Jun 13 2023

web fotografía inteligente con lightroom 5 photoclub mellado José María amazon de books

download fotografía inteligente con lightroom 5 photoclub de - Jul 02 2022

web may 5 2021 libro fotografía inteligente con lightroom 5 descargar la obra más esperada por los miles de seguidores de este autor los usuarios de lightroom y en general por todo fotógrafo en busca de una solución definitiva para organizar y

**libro fotografía inteligente con lightroom 5 descargar gratis pdf** - Sep 04 2022

web descarga libro fotografía inteligente con lightroom 5 online gratis pdf mucho más que un manual este libro es una guía de cómo conseguir que manejar miles de imágenes se convierta en una labor eficiente sencilla y gratificante mediante adobe lightroom y empleando los métodos y técnicas más depurados resultado de años de

**fotografía inteligente con lightroom 5 lardellibre cat** - Oct 05 2022

web fotografía inteligente con lightroom 5 mellado José María 49 50 mucho más que un manual este libro es una guía de cómo conseguir que manejar miles d

**photoshop lightroom cc 2020 fotoğraf düzenleme eğitim seti** - Jun 01 2022

web retouch 101 profesyonel photoshop eğitimi toplam 4 5 saatgüncellendi 01 2020 4 6 4 434 19 99 yeni başlayan fotoğrafçılar için lightroom eğitimi toplam 1 5 saatgüncellendi 06 2019 4 7 147 19 99 yeni başlayan fotoğrafçılar için

**fotografía inteligente con lightroom 5 fotografía de alta calidad** - Jan 08 2023

web fotografía inteligente con lightroom 5 47 50 la obra más esperada por los miles de seguidores de este autor los usuarios de lightroom y en general por todo fotógrafo en busca de una solución definitiva para tener el control sobre sus archivos

información adicional peso

**mamas pferd german edition kindle edition amazon com** - Aug 14 2023

web sep 3 2016 *mamas pferd german edition kindle edition by ehret angelika* download it once and read it on your kindle device pc phones or tablets use features

**mamas pferd german edition ebook kindle amazon com br** - Jul 01 2022

web viele pferde ein aufregender ausflug verstohlene küsse und eine wichtige prüfung aus merle die früher pferde überhaupt nicht mochte ist inzwischen eine begeisterte reiterin

**mamas pferd german edition retailer bonide com** - Apr 29 2022

web *mamas pferd german edition* *mamas pferd german edition 2* downloaded from *bespoke cityam com* on 2023 05 29 by guest coffee break languages has helped make

*mamas pferd german edition ebook amazon ca* - Dec 06 2022

web sep 3 2016 *mamas pferd german edition kindle edition by ehret angelika* download it once and read it on your kindle device pc phones or tablets use features

*mamas pferd pfefferminzküsse und andere prüfungen german* - Oct 04 2022

web achetez et téléchargez ebook *mamas pferd german edition boutique* kindle enfants et adolescents amazon fr

*whiskas kedi yaş mama fiyatları carrefoursa* - Feb 25 2022

web aug 20 2021 *was bedeutet mutter ein muttertier ist die mutter oder der weibliche elternteil eines pferdes wenn sie auf einer ahnentafel ein pferd als mutter sehen*

*mamas pferd german edition kindle* - Nov 05 2022

web *mamas pferd pfefferminzküsse und andere prüfungen german edition ebook ehret angelika amazon es tienda kindle*

*mamas pferd german edition kindle edition amazon co uk* - Mar 09 2023

web *mamas pferd german edition ebook ehret angelika amazon co uk kindle store*

*mamas pferd german edition format kindle amazon fr* - Sep 03 2022

web *mamas pferd german edition ebook ehret angelika amazon in kindle*

**amazon com customer reviews mamas pferd german edition** - Feb 08 2023

web find helpful customer reviews and review ratings for *mamas pferd german edition* at amazon com read honest and unbiased product reviews from our users

*mamas pferd pfefferminzküsse und andere prüfungen* - May 31 2022

web 2 *mamas pferd german edition 2019 08 07 ausgangssprache englisch five great german short stories routledge züritütsch isch aifach schön zurich german is*

[mamas pferd ebook ehret angelika amazon de kindle shop](#) - Dec 26 2021

**mamas pferd german edition ebook amazon in** - Aug 02 2022

web mamas pferd german edition ebook ehret angelika amazon com br livros pular para conteúdo principal com br olá selecione o endereço loja kindle olá faça seu

[mamas pferd pfefferminzküsse und andere prüfungen german](#) - May 11 2023

web mamas pferd pfefferminzküsse und andere prüfungen german edition ebook ehret angelika amazon in kindle store

[was ist ein mutterpferd 4everpets org](#) - Jan 27 2022

web wenn merle und ihre beste freundin laura eines nicht mögen dann sind es pferde ganz im gegensatz zu merles mutter die eine begeisterte reiterin und seit neuestem sogar

**mamas pferd german edition kindle edition amazon com au** - Apr 10 2023

web mamas pferd german edition ebook ehret angelika amazon com au kindle store

**mamas pferd pfefferminzküsse und andere prüfungen german** - Jul 13 2023

web jun 5 2020 mamas pferd pfefferminzküsse und andere prüfungen german edition kindle edition by ehret angelika download it once and read it on your kindle device

[mamas pferd traumpferde und weitere böse Überraschungen](#) - Jun 12 2023

web mamas pferd traumpferde und weitere böse Überraschungen german edition ebook ehret angelika amazon co uk kindle store

[mamas pferd german edition kindle edition](#) - Jan 07 2023

web select the department you want to search in

**mamas pferd german edition bespoke cityam com** - Mar 29 2022

web kategoriler meyve sebze meyve sebze meyve meyve sert meyveler narenciye egzotik meyveler yumuşak meyveler sebze sebze otlar yeşillikler mevsim sebzeleri

[guidelines for dialog design hci w3computing com](#) - Feb 25 2022

web guidelines for dialog design hci dialog is the communication between the computer and a person well designed dialog makes it easier for people to use a computer and lessens

**dialog design online tutorials library** - Nov 05 2022

web jul 21 2013 strong designing strong strong interfaces strong strong and strong strong dialogues strong br notes br interaction

**13 designing interface and dialogue studylib net** - Mar 09 2023

web designing interfaces and dialogues in graphical environments dialogue design issues goal is to establish the sequence of displays that users will encounter when working with

**interface design and dialogues aydin adnan menderes university** - Jul 13 2023

dialog should speak the users language use words phrases and concepts familiar to the user rather than special system terms see more

**process of designing interfaces and dialogues analytical essay** - Apr 29 2022

web for interface and dialogue designs one additional subsection is included a section outlining the dialogue sequence the ways a user can move from one display to

traditional dialogue design applied to modern user interfaces - May 11 2023

dialogs come in two main types first type are attention seeking modal dialogs which force a user to interact with them before continuing modal see more

**chapter 11 designing interfaces and dialogues** - Jan 07 2023

web designing interfaces and dialogues cont figure 11 1 systems development life 5 deliverables and outcomes creation of a design specification a typical

**dialogue design an overview sciencedirect topics** - Feb 08 2023

web ciples for good dialogue design be cause they get excited about the additional possibilities inherent in modern user interfaces as the ex amples in this article show how ever

**dialog design free dialog design templates edraw software** - Oct 24 2021

web dialog design template a free customizable dialog design template is provided to download and print quickly get a head start when creating your own windows ui

**akt2163b lecture 11 interface and dialogue design youtube** - Aug 02 2022

web lecture 11 information systems analysis and design akt2163 b class the topic is interface and dialogue design

**visual design of interaction dialog or interface** - Sep 03 2022

web these are windows that and computer and interface as the sup intuitively a good word to appear on the screen as parts of a task porting software and hardware through describe

design of dialogues for human computer interaction - May 31 2022

web jan 1 1992 the chapter reports on work conducted in three phases in the first phase examples of implemented dialogues were analysed with regard to user needs and

the design and evaluation of dialogues for interactive voice - Mar 29 2022

web of the system interface that the caller will encounter to guide their interactions user guides and on line help may be

available but the dialogue design is often key to a successful

**geocities ws** - Jan 27 2022

web interface design focuses on how information is provided to and captured from users dialogue design focuses on the sequencing of interface displays dialogues are

**interface and dialogue design secure4 khronos** - Nov 24 2021

web jun 18 2023 chapter 14 designing interfaces and dialogues additionally form and report design and interface and dialogue design have similar processes and deliverables

**outline interface design roadmap navigation and dialogue** - Jul 01 2022

web outline interface design roadmap navigation and dialogue static structure diagrams jsd diagram navigation and dialogue hci lecture 7 david aspinall informatics

**visual design of interaction dialog or interface researchgate** - Sep 22 2021

web jan 11 1995 this survey presents important concepts of interface management dialogue independence structural modeling representation interactive tools rapid prototyping

*modern systems analysis and design ch1 computer science* - Apr 10 2023

web dr samsun m baŞarici cse 414 systems analysis and design lecture 10 designing interfaces and dialogues learning objectives explain the process of designing

**chapter 11 designing interfaces and dialogues yumpu** - Dec 06 2022

web dialogue design the dialogue design process remains an art as well as a science from handbook of human computer interaction 1988 related terms ergonomics

**5 essential ux rules for dialog design** - Aug 14 2023

use dialogs sparingly because they are interruptive their sudden appearance forces users to stop their current task and focus on the dialog content for modal dialogs users have to deal with a in dialog action before continuing and are no longer able to access the page below sometimes this is a good thing such as see more

**user interface design wikipedia** - Oct 04 2022

web a dialog is the construction of interaction between two or more beings or systems in hci a dialog is studied at three levels lexical shape of icons actual keys pressed etc are

**chapter14 designing interfaces and dialogues slideshare** - Jun 12 2023

you shouldn t try to cram too much into a dialog keep it clean and simple follow the kiss principle but minimalist doesn t mean limited all information should be valuable and relevant see more

interactive design of web user interface adaptive display - Dec 26 2021

web may 12 2019 in the overall web user interface adaptive design including the most important two design elements namely human and interactive interface dialogue