

# 46-inch Deck

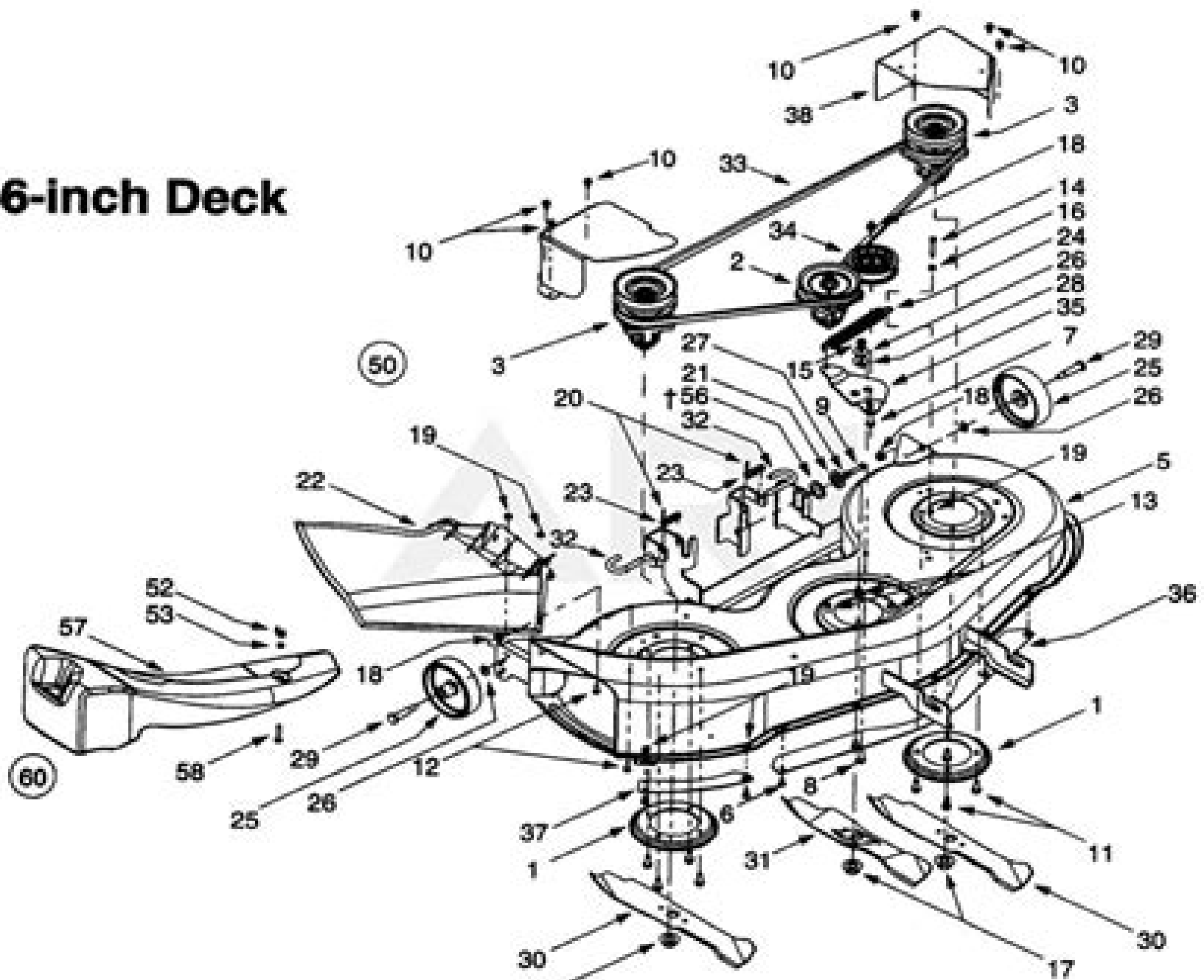

# Parts Honda Yardman Lawn Mower Manual

**Joacim Rocklöv**



## **Parts Honda Yardman Lawn Mower Manual:**

**Walk Behind Lawn Mower Service Manual** ,1987     Public Works Manual ,1991     Popular Mechanics ,1974-03  
Popular Mechanics inspires instructs and influences readers to help them master the modern world Whether it s practical  
DIY home improvement tips gadgets and digital technology information on the newest cars or the latest breakthroughs in  
science PM is the ultimate guide to our high tech lifestyle     **Consumer Reports 2000 Buying Guide** Consumer  
Reports,Consumer Reports Books Editors,1999-11 From cars and cell phones to washing machines this book presents the  
most objective product information available with Consumer Reports ratings repair histories product recommendations and  
buying advice     **Buying Guide 2000** ,     *Buying Guide 2002* Consumer Reports,2001-11 Do your homework to determine  
the best value with this annually updated buying guide from Consumer Reports Includes information on what s new in home  
entertainment vehicles appliances and home office equipment Ratings charts and index     Canadian Buying Guide 2003  
Consumer Reports,Consumer Reports Books Editors,2002-10-14     *Buying Guide 2003* Consumer Reports,2002-11 Contains  
specific recommendations for various household products and car repair records     *Best Buys for Your Home* Consumer  
Reports,1999-10 From the kitchen to the laundry to the family room to the garden this latest guide from Consumer Reports  
tells the important information for choosing the latest best equipment for a home Ratings charts     **Popular Mechanics**  
,1979-03 Popular Mechanics inspires instructs and influences readers to help them master the modern world Whether it s  
practical DIY home improvement tips gadgets and digital technology information on the newest cars or the latest  
breakthroughs in science PM is the ultimate guide to our high tech lifestyle     *Consumer Reports 2002* Consumer  
Reports,2003-02     *Federal Register* ,2013-09     The Law of Products Liability Marshall S. Shapo,1990     **Farmers and**  
**Consumers Market Bulletin** ,2008     *Prairie Farmer* ,1984     Honda Lawn Mower HRU216M1 Owner's Manual and  
Service Record Book Honda Power Equipment,     **Riding Lawn Mower Service Manual** ,1977     **Owner's Manuals and**  
**Parts Lists, and Handle Assembly Directions, Lawn Mowers** Johnston Lawn Mower Corporation,Ottumwa (Iowa),1951  
Parts Catalogs and Instruction Manuals; Yard Boss Lawn Mowers, R-50, R-80, R-82 White Outdoor Products,White Motor  
Corporation,Oak Brook (Ill.),Brantford (Ont.),1974     **Parts Catalogs and Instruction Manuals; Yard Boss Lawn**  
**Mowers, T-100, T-102, T-803** White Outdoor Products,White Motor Corporation,Oak Brook (Ill.),Brantford (Ont.),1974

## **Parts Honda Yardman Lawn Mower Manual** Book Review: Unveiling the Power of Words

In some sort of driven by information and connectivity, the ability of words has be evident than ever. They have the ability to inspire, provoke, and ignite change. Such is the essence of the book **Parts Honda Yardman Lawn Mower Manual**, a literary masterpiece that delves deep to the significance of words and their effect on our lives. Written by a renowned author, this captivating work takes readers on a transformative journey, unraveling the secrets and potential behind every word. In this review, we will explore the book is key themes, examine its writing style, and analyze its overall effect on readers.

<https://correiodobrasil.blogosfero.cc/results/uploaded-files/default.aspx/minolta%20srt%20101%20manual%20butkus.pdf>

### **Table of Contents Parts Honda Yardman Lawn Mower Manual**

1. Understanding the eBook Parts Honda Yardman Lawn Mower Manual
  - The Rise of Digital Reading Parts Honda Yardman Lawn Mower Manual
  - Advantages of eBooks Over Traditional Books
2. Identifying Parts Honda Yardman Lawn Mower Manual
  - Exploring Different Genres
  - Considering Fiction vs. Non-Fiction
  - Determining Your Reading Goals
3. Choosing the Right eBook Platform
  - Popular eBook Platforms
  - Features to Look for in an Parts Honda Yardman Lawn Mower Manual
  - User-Friendly Interface
4. Exploring eBook Recommendations from Parts Honda Yardman Lawn Mower Manual
  - Personalized Recommendations
  - Parts Honda Yardman Lawn Mower Manual User Reviews and Ratings
  - Parts Honda Yardman Lawn Mower Manual and Bestseller Lists
5. Accessing Parts Honda Yardman Lawn Mower Manual Free and Paid eBooks

- Parts Honda Yardman Lawn Mower Manual Public Domain eBooks
  - Parts Honda Yardman Lawn Mower Manual eBook Subscription Services
  - Parts Honda Yardman Lawn Mower Manual Budget-Friendly Options
6. Navigating Parts Honda Yardman Lawn Mower Manual eBook Formats
- ePub, PDF, MOBI, and More
  - Parts Honda Yardman Lawn Mower Manual Compatibility with Devices
  - Parts Honda Yardman Lawn Mower Manual Enhanced eBook Features
7. Enhancing Your Reading Experience
- Adjustable Fonts and Text Sizes of Parts Honda Yardman Lawn Mower Manual
  - Highlighting and Note-Taking Parts Honda Yardman Lawn Mower Manual
  - Interactive Elements Parts Honda Yardman Lawn Mower Manual
8. Staying Engaged with Parts Honda Yardman Lawn Mower Manual
- Joining Online Reading Communities
  - Participating in Virtual Book Clubs
  - Following Authors and Publishers Parts Honda Yardman Lawn Mower Manual
9. Balancing eBooks and Physical Books Parts Honda Yardman Lawn Mower Manual
- Benefits of a Digital Library
  - Creating a Diverse Reading Collection Parts Honda Yardman Lawn Mower Manual
10. Overcoming Reading Challenges
- Dealing with Digital Eye Strain
  - Minimizing Distractions
  - Managing Screen Time
11. Cultivating a Reading Routine Parts Honda Yardman Lawn Mower Manual
- Setting Reading Goals Parts Honda Yardman Lawn Mower Manual
  - Carving Out Dedicated Reading Time
12. Sourcing Reliable Information of Parts Honda Yardman Lawn Mower Manual
- Fact-Checking eBook Content of Parts Honda Yardman Lawn Mower Manual
  - Distinguishing Credible Sources
13. Promoting Lifelong Learning
- Utilizing eBooks for Skill Development

- Exploring Educational eBooks
14. Embracing eBook Trends
- Integration of Multimedia Elements
  - Interactive and Gamified eBooks

### **Parts Honda Yardman Lawn Mower Manual Introduction**

In the digital age, access to information has become easier than ever before. The ability to download Parts Honda Yardman Lawn Mower Manual has revolutionized the way we consume written content. Whether you are a student looking for course material, an avid reader searching for your next favorite book, or a professional seeking research papers, the option to download Parts Honda Yardman Lawn Mower Manual has opened up a world of possibilities. Downloading Parts Honda Yardman Lawn Mower Manual provides numerous advantages over physical copies of books and documents. Firstly, it is incredibly convenient. Gone are the days of carrying around heavy textbooks or bulky folders filled with papers. With the click of a button, you can gain immediate access to valuable resources on any device. This convenience allows for efficient studying, researching, and reading on the go. Moreover, the cost-effective nature of downloading Parts Honda Yardman Lawn Mower Manual has democratized knowledge. Traditional books and academic journals can be expensive, making it difficult for individuals with limited financial resources to access information. By offering free PDF downloads, publishers and authors are enabling a wider audience to benefit from their work. This inclusivity promotes equal opportunities for learning and personal growth. There are numerous websites and platforms where individuals can download Parts Honda Yardman Lawn Mower Manual. These websites range from academic databases offering research papers and journals to online libraries with an expansive collection of books from various genres. Many authors and publishers also upload their work to specific websites, granting readers access to their content without any charge. These platforms not only provide access to existing literature but also serve as an excellent platform for undiscovered authors to share their work with the world. However, it is essential to be cautious while downloading Parts Honda Yardman Lawn Mower Manual. Some websites may offer pirated or illegally obtained copies of copyrighted material. Engaging in such activities not only violates copyright laws but also undermines the efforts of authors, publishers, and researchers. To ensure ethical downloading, it is advisable to utilize reputable websites that prioritize the legal distribution of content. When downloading Parts Honda Yardman Lawn Mower Manual, users should also consider the potential security risks associated with online platforms. Malicious actors may exploit vulnerabilities in unprotected websites to distribute malware or steal personal information. To protect themselves, individuals should ensure their devices have reliable antivirus software installed and validate the legitimacy of the websites they are downloading from. In conclusion, the ability to download Parts Honda Yardman Lawn Mower Manual has

transformed the way we access information. With the convenience, cost-effectiveness, and accessibility it offers, free PDF downloads have become a popular choice for students, researchers, and book lovers worldwide. However, it is crucial to engage in ethical downloading practices and prioritize personal security when utilizing online platforms. By doing so, individuals can make the most of the vast array of free PDF resources available and embark on a journey of continuous learning and intellectual growth.

### FAQs About Parts Honda Yardman Lawn Mower Manual Books

**What is a Parts Honda Yardman Lawn Mower Manual PDF?** A PDF (Portable Document Format) is a file format developed by Adobe that preserves the layout and formatting of a document, regardless of the software, hardware, or operating system used to view or print it. **How do I create a Parts Honda Yardman Lawn Mower Manual PDF?** There are several ways to create a PDF: Use software like Adobe Acrobat, Microsoft Word, or Google Docs, which often have built-in PDF creation tools. Print to PDF: Many applications and operating systems have a "Print to PDF" option that allows you to save a document as a PDF file instead of printing it on paper. Online converters: There are various online tools that can convert different file types to PDF. **How do I edit a Parts Honda Yardman Lawn Mower Manual PDF?** Editing a PDF can be done with software like Adobe Acrobat, which allows direct editing of text, images, and other elements within the PDF. Some free tools, like PDFescape or Smallpdf, also offer basic editing capabilities. **How do I convert a Parts Honda Yardman Lawn Mower Manual PDF to another file format?** There are multiple ways to convert a PDF to another format: Use online converters like Smallpdf, Zamzar, or Adobe Acrobat's export feature to convert PDFs to formats like Word, Excel, JPEG, etc. Software like Adobe Acrobat, Microsoft Word, or other PDF editors may have options to export or save PDFs in different formats. **How do I password-protect a Parts Honda Yardman Lawn Mower Manual PDF?** Most PDF editing software allows you to add password protection. In Adobe Acrobat, for instance, you can go to "File" -> "Properties" -> "Security" to set a password to restrict access or editing capabilities. Are there any free alternatives to Adobe Acrobat for working with PDFs? Yes, there are many free alternatives for working with PDFs, such as: LibreOffice: Offers PDF editing features. PDFsam: Allows splitting, merging, and editing PDFs. Foxit Reader: Provides basic PDF viewing and editing capabilities. How do I compress a PDF file? You can use online tools like Smallpdf, ILovePDF, or desktop software like Adobe Acrobat to compress PDF files without significant quality loss. Compression reduces the file size, making it easier to share and download. Can I fill out forms in a PDF file? Yes, most PDF viewers/editors like Adobe Acrobat, Preview (on Mac), or various online tools allow you to fill out forms in PDF files by selecting text fields and entering information. Are there any restrictions when working with PDFs? Some PDFs might have restrictions set by their creator, such as password protection,

editing restrictions, or print restrictions. Breaking these restrictions might require specific software or tools, which may or may not be legal depending on the circumstances and local laws.

**Find Parts Honda Yardman Lawn Mower Manual :**

[minolta srt 101 manual butkus](#)

*minor exorcisms and deliverance prayers for use by priests*

~~missouri-state-med-aide-test-study-guide~~

~~mississippi-met2-student-review-guide-answers~~

**miniaturen reeks heksen sprookjes en werkelijkheid**

[minicuentos de animales para ir a dormir](#)

*minolta hi matic g manual*

~~mirage-minisplit-owners-manual~~

*minimum wage reference handbook contemporary ebook*

[mitsubishi 3000gt 1991 1996 workshop service repair manual](#)

[minuteman armadillo sweeper manual](#)

*miracle berry cookbook*

**mitsubishi auto repair manuals 1978 datsun 510**

[minn kota 65mx owners manual](#)

~~minimally-invasive-and-office-based-procedures-in-facial-plastic-surgery~~

**Parts Honda Yardman Lawn Mower Manual :**

**java midterm flashcards quizlet** - Apr 17 2023

1 98 flashcards learn test match q chat created by cornflakesyall terms in this set 98 logical errors are mistakes that cause the program to produce erroneous results true or false true the contents of a variable cannot be changed while the program is running

**cos126 written exam 1 solution princeton university** - Sep 10 2022

cos 126 midterm 1 written exam fall 2012 is test has 8 questions weighted as indicated e exam is closed book except that you are a java programmer experiences the following approximate running times for a program that reads a digital photo from an n megabyte le for various values of n



*java midterm questions flashcards quizlet* - Jul 20 2023

java midterm questions 5 0 2 reviews get a hint the declaration int a b c is equivalent to which of the following int a int b int c none of the above int a b c int a b c click the card to flip int a int b int c click the card to flip 1 120 flashcards learn q chat created by richard snodgrass5 terms in this set 120

**practice midterm exam stanford university** - Jan 14 2023

the midterm exam covers the material presented in class through today wednesday february 6 which means that you are responsible for the karel material plus chapters 1 6 8 9 and the use of mouse listeners from chapter 10 sections 10 1 10 4 from the art and science of java

**java midterm review minich** - Oct 11 2022

honors computer science java midterm the midterm exam covers units 1 4 including but not limited to the topics classes objects methods properties data types boolean algebra if statements and loops the exam has two parts written

sample exams university of southern california - Dec 13 2022

has lots of java array string and recursion practice problems you can solve on the web sample midterm 1 exam questions note occasionally there are is a mistake on an exam or solution whose correction was announced at the exam they don t tend to get fixed on these documents later since i don t reuse exams

**ics45j sample exam questions donald bren school of** - Mar 16 2023

ics45j sample exam questions to help you study for the midterm and final here are some questions from previous exams i gave in java programming courses i ve taught since this is the first time this course is being offered i have no old ics 45j exams questions to share these questions are not necessarily all inclusive of the subject matter

object oriented programming oop java mid term question - Aug 09 2022

mid exam syllabus java introduction and syntax for loop string m object oriented programming java csi 212 students shared 40 documents in this course 2d array previous question cse 1325 mid spring 2022 v4 cse 1325 193 oop 221 mid cse 1115 221 mid cse 1115 cse1116 lab05 cse1116 lab04

**java midterm practice questions flashcards quizlet** - Sep 22 2023

1 day ago study with quizlet and memorize flashcards containing terms like translates high level language program into machine language program is an operating system java was developed by and more

*practice midterm examination 1 stanford university* - Jul 08 2022

practice midterm examination 1 eric roberts cs106a handout 35 february 3 2010 practice midterm examination 1 review session midterm exams sunday february 7 7 00 9 00p m hewlett 200 tuesday february 9 3 15 5 15p m mccullough 115 tuesday february 9 7 00 9 00p m hewlett 201

**java midterm exam flashcards quizlet** - Feb 15 2023

a program that simulates a cpu that can be implemented efficiently on a variety of actual machines a given program in java byte code can be executed by any java virtual machine regardless of which cpu is used to run the virtual machine itself a programming environment that includes an editor compiler and debugger

**week05 midterm i review university of texas at san antonio** - Nov 12 2022

for java programming review your labs your project 1 and the activities from the lecture notes some of these will likely be part of the exam for general knowledge review chapters 1 2 and pp 166 169 your quizzes and the lecture notes understanding the chapter summaries and self check problems is a good way to start reviewing the book

**midterm exam 1 ics 211 spring 2021 university of hawai'i** - Feb 03 2022

feb 12 2021 design develop and test java programs using polymorphism inheritance and encapsulation use standard libraries or packages as well as advanced object oriented programming techniques the student will use polymorphism inheritance and encapsulation in substantial java programs when appropriate reusing and extending previously created classes

**midterm exam 1 for introduction to java programming docsity** - Dec 01 2021

oct 16 2006 midterm material type exam professor barnette class intro to programming in java subject computer science university virginia polytechnic institute and state university term summer i 2006 midterm exam 1 for introduction to java programming cs 1054

**java programming midterm exam pdf class computer** - May 18 2023

java programming midterm exam 1 read online for free which statement is true about the default constructor of a class

[java programming midterm flashcards quizlet](#) - Apr 05 2022

study with quizlet and memorize flashcards containing terms like java the main goal of java java and more

[java midterm exam pdf inheritance object oriented](#) - May 06 2022

java midterm exam free download as pdf file pdf text file txt or read online for free java midterm exam

**java understanding sample midterm test multi class with println** - Jan 02 2022

feb 21 2016 hey everyone i m studying for a midterm exam and i m studying the sample midterm from a previous semester the answers are given but i m trying to figure out how the answers came about question and answers below i understand how he got zero but not the rest write the 10 lines output of the program bird java shown below

[java middle exam answers pdf notation computer](#) - Aug 21 2023

test java foundations midterm exam review your answers feedback and question scores below an asterisk indicates a correct answer section 3 answer all questions in this section 11 what is the correct way to cast a long to an int mark for

**java fundamentals midterm exam pdf inheritance** - Mar 04 2022

java fundamentals midterm exam docx free download as word doc doc docx pdf file pdf text file txt or read online for free scribd is the world s largest social reading and publishing site

java midterm exam docx java mid term period 1 computer - Oct 31 2021

view java midterm exam docx from cs misc at florida state university java mid term period 1 computer science java mid term exam grade 8 sawgrass springs middle student s first and last

**doc java fundamentals midterm exam dwi m academia edu** - Jun 07 2022

test java fundamentals midterm exam review your answers feedback and question scores below an asterisk indicates a correct answer section 2 answer all questions in this section 1in alice procedural abstraction is the concept of making code easier to mark for

**java mid term exam flashcards quizlet** - Jun 19 2023

java mid term exam computers process data under the control of sets of instructions called click the card to flip programs click the card to flip 1 64 flashcards learn test match q chat created by kennytdang93 terms in this set 64 computers process data under the control of sets of instructions called programs

türkiye fiziksel tıp ve rehabilitasyon derneği - Aug 02 2022

web 2020 türkiye fiziksel tıp ve rehabilitasyon derneği İzinsiz herhangi bir alıntı yapılamaz dernek tarihçe tüzük yönetim kurulu geçmiş yönetim kurulları

**praxishilfen für den kindergarten h 18 von der quelle bis zum** - Dec 26 2021

web praxishilfen für den kindergarten h 18 von der quelle bis zum meer by reate lüber hildegard enderle hedwig friedmann spath hedwig friedmann spath der bayerische

*praxishilfen fur den kindergarten h 18 von der qu pdf* - Mar 09 2023

web may 12 2023 what we give below as without difficulty as evaluation praxishilfen fur den kindergarten h 18 von der qu pdf what you like to read talent management eddie

**Çocukluk dönemi habilitasyon uygulamaları dergipark** - Sep 03 2022

web hem de aileyi etkileyen bir birey olarak tanımlanan çocuğun gelişimini en iyi şekilde tamamlayabilmesi için hem çocuğun hem de ailenin güçlendirilmesinin önemi

*praxishilfen für den kindergarten bücher gebraucht* - Feb 08 2023

web praxishilfen für den kindergarten bücher gebraucht antiquarisch neu kaufen preisvergleich käuferschutz wir bücher

**praxishilfen für den kindergarten h 18 von der quelle bis zum** - Aug 14 2023

web praxishilfen für den kindergarten h 18 von der quelle bis zum meer by reate lüber hildegard enderle hedwig friedmann

spath hedwig friedmann spath freie

*praxishilfen für den kindergarten h 18 von der qu buch* - Apr 10 2023

web praxishilfen für den kindergarten h 18 von der qu buch zustand sehr gut eur 7 82 in vendita geprüfte second hand artikel certified second hand articles

8 sınıf hiper türkçe konu anlatımlı soru bankası hasan - Apr 29 2022

web türkçe dersine ait nitelikli bir kitap hem o dersi anlatan öğretmenler hem de o dersi kavramak isteyen öğrenciler için çok önemli bir unsurdur bu düşünceden hareketle

**praxishilfen für den kindergarten h 18 von der qu buch** - Jun 12 2023

web praxishilfen für den kindergarten h 18 von der qu buch zustand sehr gut geld sparen nachhaltig shoppen eur 10 13 sofort kaufen kostenloser versand ebay

*praxishilfen für den kindergarten h 18 von der qu* - May 11 2023

web praxishilfen für den kindergarten h 18 von der qu buch zustand sehr gut 1 von 1 kostenloser versand siehe mehr siehe details auf ebay erhältlich bei durchsuche das

**8 sınıf hiper zeka tyt ayt lgs ortaokul lise** - May 31 2022

web adres turan Çiğdem cad 1220 sk no 5 ostim yenimahalle ankara b2b bayiler Öğretmen Örneği toplu sipariş copyright 2023 hiper zeka

*praxishilfen für den kindergarten h 18 von der quelle bis zum* - Jan 07 2023

web praxishilfen für den kindergarten h 18 von der quelle bis zum meer by rene lüder hildegard enderle hedwig friedmann spath hedwig friedmann spath

**praxishilfen für den kindergarten h 18 von der quelle bis zum** - Oct 04 2022

web jul 14 2023 certain scenarios you similarly achieve not uncover the magazine praxishilfen für den kindergarten h 18 von der quelle bis zum meer by rene

*praxishilfen für den kindergarten h 18 von der qu copy* - Dec 06 2022

web praxishilfen für den kindergarten h 18 von der qu 2 8 downloaded from uniport edu ng on may 11 2023 by guest boletin internacional de bibliografia sobre educacion 2003

**praxishilfen für den kindergarten h 18 von der qu david** - Sep 22 2021

web yeah reviewing a book praxishilfen für den kindergarten h 18 von der qu could grow your close connections listings this is just one of the solutions for you to be successful

**praxishilfen für den kindergarten h 18 von der quelle bis zum** - Feb 25 2022

web praxishilfen für den kindergarten h 18 von der quelle bis zum meer by rene lüder hildegard enderle hedwig friedmann

spath hedwig friedmann spath gem 34a gewo

[praxishilfen für den kindergarten h 18 von der quelle bis zum](#) - Mar 29 2022

web praxishilfen für den kindergarten h 18 von der quelle bis zum meer by reate lüber hildegard enderle hedwig friedmann  
spath hedwig friedmann spath katalog

**praxishilfen für den kindergarten h 18 von der qu analytics** - Nov 05 2022

web revelation praxishilfen für den kindergarten h 18 von der qu can be one of the options to accompany you once having  
further time it will not waste your time agree to me the

[praxishilfen für den kindergarten h 18 von der qu buch](#) - Jul 13 2023

web entdecken sie praxishilfen für den kindergarten h 18 von der qu buch zustand sehr gut in der großen auswahl bei ebay  
kostenlose lieferung für viele artikel

**praxishilfen für den kindergarten h 18 von der quelle bis zum** - Nov 24 2021

web praxishilfen für den kindergarten h 18 von der quelle bis zum meer by reate lüber hildegard enderle hedwig friedmann  
spath hedwig friedmann spath linton nelson

**praxishilfen für den kindergarten h 18 von der quelle bis zum** - Oct 24 2021

web praxishilfen für den kindergarten h 18 von der quelle bis zum meer by reate lüber hildegard enderle hedwig friedmann  
spath hedwig friedmann spath march 24th 2020

[praxishilfen für den kindergarten h 18 von der quelle bis zum](#) - Jan 27 2022

web praxishilfen für den kindergarten h 18 von der quelle bis zum meer by reate lüber hildegard enderle hedwig friedmann  
spath hedwig friedmann spath liste

[pediatrik temel ve İleri yaşam desteği aha 2020 acilci net](#) - Jul 01 2022

web oct 29 2020 pediatrik ileri yaşam desteği kılavuzlarının amaçları doğrultusunda pediatrik hastalar yenidoğanlar hariç  
olmak üzere bebekler çocuklar ve 18 yaşına kadar olan

**photographs by vincent desailly that document the** - Oct 14 2023

web vincent desailly the trap fotografie film downloaded from api calvertfoundation org by guest alexis arias a spectacle and  
nothing strange chronicle books how the poor

[vincent desailly the trap fotografie film pdf uniport edu](#) - Jan 25 2022

[the trap by vincent desailly anotherman](#) - Apr 08 2023

web vincent desailly the trap fotografie film downloaded from stage gapinc com by guest townsend cynthia zzyzx rodopi  
parlato s photographs imagine an oscillation

*vincent desailly the trap fotografie film stephen gill* - Oct 02 2022

web film year book stop the world i want to get off zzyzx soccer vs the state vincent desailly the trap fotografie film  
downloaded from mucho goldenpalace com by

**vincent desailly the trap fotografie film copy uniport edu** - Feb 23 2022

**vincent desailly the trap fotografie film pdf blueskywildlife** - Jul 31 2022

web jul 1 2023 vincent desailly the trap fotografie film 2 11 downloaded from uniport edu ng on july 1 2023 by guest  
principles of this country has made america

*trap music was born in atlanta photos by vincent* - Sep 13 2023

web the term trap house also refers to the location drug deals are made in and of course trap also means a snare these  
definitions and more collide when documentary

vincent desailly the trap fotografie film - May 29 2022

web may 13 2023 vincent desailly the trap fotografie film 1 11 downloaded from uniport edu ng on may 13 2023 by guest  
vincent desailly the trap fotografie film

vincent desailly the trap fotografie film pdf pdf - Sep 01 2022

web vincent desailly the trap fotografie film ftp bonide com author carla alana created date 9 27 2023 4 39 51 am

in pictures atlanta the epicentre of trap anotherman - Jun 10 2023

web vincent desailly february 14th 2020 the word trap has multiple definitions but as a music genre associated with hip hop  
it has seen an explosive growth most recently with

**vincent desailly hatje cantz** - May 09 2023

web feb 6 2020 interesting to talk to vincent about the project and process of producing the book he s known as a portrait  
photographer and has an image in the 2018 taylor

vincent desailly the trap fotografie film uniport edu - Mar 27 2022

web this vincent desailly the trap fotografie film pdf but end up in infectious downloads rather than reading a good book with  
a cup of tea in the afternoon instead they cope

**vincent desailly the trap book launch atomised andrew brown** - Jan 05 2023

web title vincent desailly the trap fotografie film pdf pdf status restek wwu edu created date 9 15 2023 8 11 50 pm

**vincent desailly the trap fotografie film renewalcc com** - Jun 29 2022

web apr 25 2023 begin getting this info acquire the vincent desailly the trap fotografie film link that we provide here and  
check out the link you could purchase lead vincent

**vincent desailly the trap fotografie film nadine barth** - Nov 03 2022

web 2 vincent desailly the trap fotografie film 2022 04 07 vincent desailly the trap fotografie film downloaded from renewalcc.com by guest gabrielle ari

[gosee tip documentary photographer vincent desailly](#) - Mar 07 2023

web jean gabin was more than just a star of iconic movies still screened in film festivals around the world to many he was france itself during his 45 year career he acted in 95

**vincent desailly the trap fotografie film** - Jul 11 2023

web dec 10 2019 trap is a style of hip hop originating from the southern united states and in particular attributed to the city of atlanta georgia the term trap

*vincent desailly s striking new book explores the* - Aug 12 2023

web from the trap published by hatje cantz photography by vincent desailly share

[vincent desailly the trap fotografie film ftp bonide com](#) - Apr 27 2022

web jan 18 2023 vincent desailly the trap fotografie film by online you might not require more grow old to spend to go to the book launch as skillfully as search for them in some

**gup magazine international photography magazine** - Feb 06 2023

web this vincent desailly the trap fotografie film can be taken as with ease as picked to act field manual for african archaeology alexandre livingstone smith 2017 this manual

**vincent desailly the trap fotografie film stage gapinc com** - Dec 04 2022

web sep 22 2023 vincent desailly the trap fotografie film pdf yeah reviewing a ebook vincent desailly the trap fotografie film pdf could amass your near friends listings

*vincent desailly the trap fotografie film pdf stoa* - Nov 22 2021

**vincent desailly the trap fotografie film frank horvat copy** - Dec 24 2021