

MURRAY ROTARY LAWN MOWER - MODEL NUMBER M22500 (MFG. I.D. NO. 96114002900)

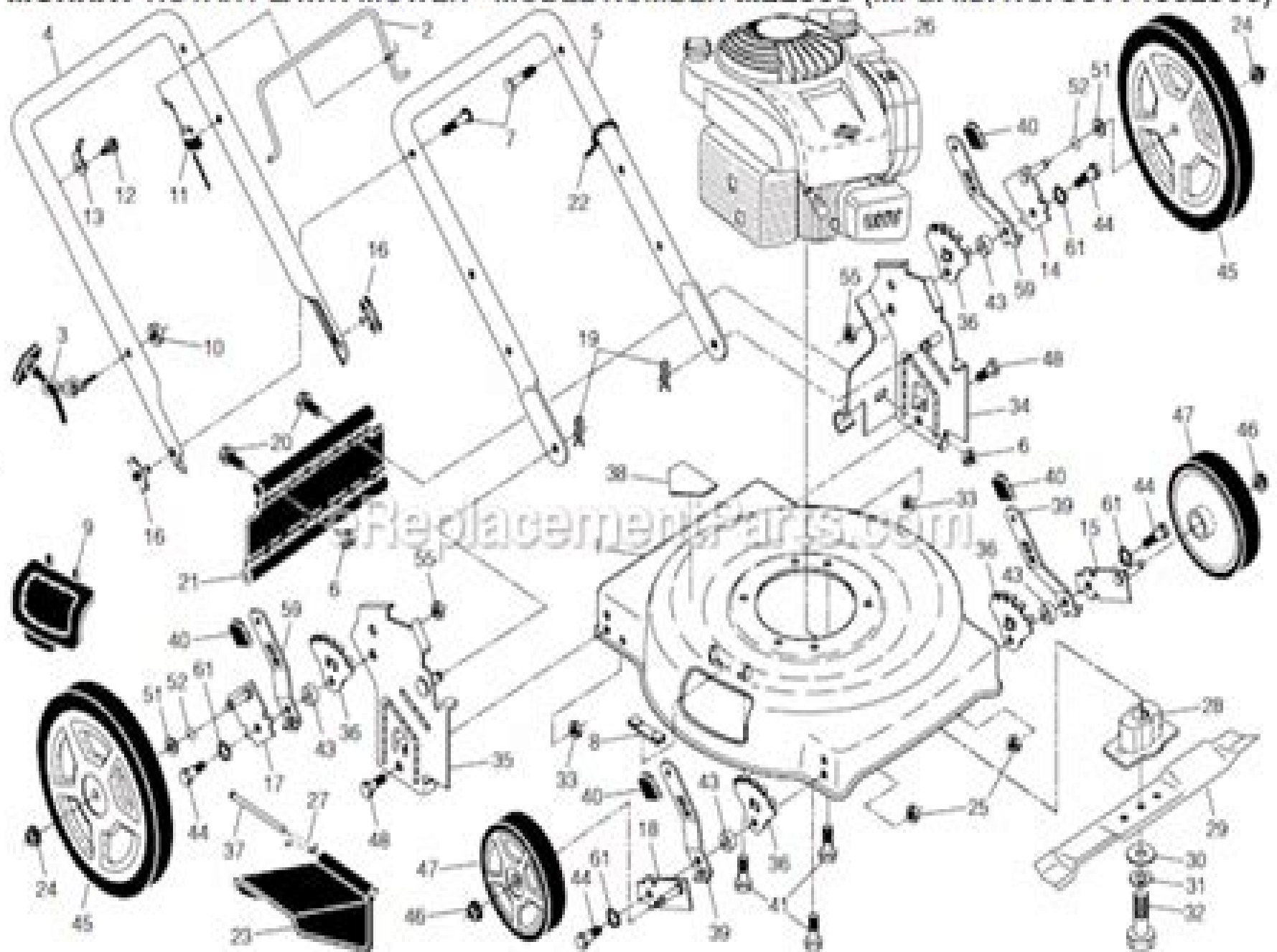

Murray 96114002900 Manual

ML Morrison



Murray 96114002900 Manual:

Yeah, reviewing a books **Murray 96114002900 Manual** could grow your near connections listings. This is just one of the solutions for you to be successful. As understood, ability does not suggest that you have extraordinary points.

Comprehending as capably as treaty even more than extra will provide each success. bordering to, the publication as with ease as perspicacity of this Murray 96114002900 Manual can be taken as skillfully as picked to act.

<https://correiodobrasil.blogosfero.cc/results/virtual-library/default.aspx/Nokia%205800%20Xpressmusic%20Users%20Guide.pdf>

Table of Contents Murray 96114002900 Manual

1. Understanding the eBook Murray 96114002900 Manual
 - The Rise of Digital Reading Murray 96114002900 Manual
 - Advantages of eBooks Over Traditional Books
2. Identifying Murray 96114002900 Manual
 - Exploring Different Genres
 - Considering Fiction vs. Non-Fiction
 - Determining Your Reading Goals
3. Choosing the Right eBook Platform
 - Popular eBook Platforms
 - Features to Look for in an Murray 96114002900 Manual
 - User-Friendly Interface
4. Exploring eBook Recommendations from Murray 96114002900 Manual
 - Personalized Recommendations
 - Murray 96114002900 Manual User Reviews and Ratings
 - Murray 96114002900 Manual and Bestseller Lists
5. Accessing Murray 96114002900 Manual Free and Paid eBooks
 - Murray 96114002900 Manual Public Domain eBooks

- Murray 96114002900 Manual eBook Subscription Services
- Murray 96114002900 Manual Budget-Friendly Options
- 6. Navigating Murray 96114002900 Manual eBook Formats
 - ePub, PDF, MOBI, and More
 - Murray 96114002900 Manual Compatibility with Devices
 - Murray 96114002900 Manual Enhanced eBook Features
- 7. Enhancing Your Reading Experience
 - Adjustable Fonts and Text Sizes of Murray 96114002900 Manual
 - Highlighting and Note-Taking Murray 96114002900 Manual
 - Interactive Elements Murray 96114002900 Manual
- 8. Staying Engaged with Murray 96114002900 Manual
 - Joining Online Reading Communities
 - Participating in Virtual Book Clubs
 - Following Authors and Publishers Murray 96114002900 Manual
- 9. Balancing eBooks and Physical Books Murray 96114002900 Manual
 - Benefits of a Digital Library
 - Creating a Diverse Reading Collection Murray 96114002900 Manual
- 10. Overcoming Reading Challenges
 - Dealing with Digital Eye Strain
 - Minimizing Distractions
 - Managing Screen Time
- 11. Cultivating a Reading Routine Murray 96114002900 Manual
 - Setting Reading Goals Murray 96114002900 Manual
 - Carving Out Dedicated Reading Time
- 12. Sourcing Reliable Information of Murray 96114002900 Manual
 - Fact-Checking eBook Content of Murray 96114002900 Manual
 - Distinguishing Credible Sources
- 13. Promoting Lifelong Learning
 - Utilizing eBooks for Skill Development
 - Exploring Educational eBooks

14. Embracing eBook Trends

- Integration of Multimedia Elements
- Interactive and Gamified eBooks

Murray 96114002900 Manual Introduction

Free PDF Books and Manuals for Download: Unlocking Knowledge at Your Fingertips In today's fast-paced digital age, obtaining valuable knowledge has become easier than ever. Thanks to the internet, a vast array of books and manuals are now available for free download in PDF format. Whether you are a student, professional, or simply an avid reader, this treasure trove of downloadable resources offers a wealth of information, conveniently accessible anytime, anywhere. The advent of online libraries and platforms dedicated to sharing knowledge has revolutionized the way we consume information. No longer confined to physical libraries or bookstores, readers can now access an extensive collection of digital books and manuals with just a few clicks. These resources, available in PDF, Microsoft Word, and PowerPoint formats, cater to a wide range of interests, including literature, technology, science, history, and much more. One notable platform where you can explore and download free Murray 96114002900 Manual PDF books and manuals is the internet's largest free library. Hosted online, this catalog compiles a vast assortment of documents, making it a veritable goldmine of knowledge. With its easy-to-use website interface and customizable PDF generator, this platform offers a user-friendly experience, allowing individuals to effortlessly navigate and access the information they seek. The availability of free PDF books and manuals on this platform demonstrates its commitment to democratizing education and empowering individuals with the tools needed to succeed in their chosen fields. It allows anyone, regardless of their background or financial limitations, to expand their horizons and gain insights from experts in various disciplines. One of the most significant advantages of downloading PDF books and manuals lies in their portability. Unlike physical copies, digital books can be stored and carried on a single device, such as a tablet or smartphone, saving valuable space and weight. This convenience makes it possible for readers to have their entire library at their fingertips, whether they are commuting, traveling, or simply enjoying a lazy afternoon at home. Additionally, digital files are easily searchable, enabling readers to locate specific information within seconds. With a few keystrokes, users can search for keywords, topics, or phrases, making research and finding relevant information a breeze. This efficiency saves time and effort, streamlining the learning process and allowing individuals to focus on extracting the information they need. Furthermore, the availability of free PDF books and manuals fosters a culture of continuous learning. By removing financial barriers, more people can access educational resources and pursue lifelong learning, contributing to personal growth and professional development. This democratization of knowledge promotes intellectual curiosity and empowers individuals to become lifelong learners, promoting progress and innovation in various fields. It is worth noting that while

accessing free Murray 96114002900 Manual PDF books and manuals is convenient and cost-effective, it is vital to respect copyright laws and intellectual property rights. Platforms offering free downloads often operate within legal boundaries, ensuring that the materials they provide are either in the public domain or authorized for distribution. By adhering to copyright laws, users can enjoy the benefits of free access to knowledge while supporting the authors and publishers who make these resources available. In conclusion, the availability of Murray 96114002900 Manual free PDF books and manuals for download has revolutionized the way we access and consume knowledge. With just a few clicks, individuals can explore a vast collection of resources across different disciplines, all free of charge. This accessibility empowers individuals to become lifelong learners, contributing to personal growth, professional development, and the advancement of society as a whole. So why not unlock a world of knowledge today? Start exploring the vast sea of free PDF books and manuals waiting to be discovered right at your fingertips.

FAQs About Murray 96114002900 Manual Books

How do I know which eBook platform is the best for me? Finding the best eBook platform depends on your reading preferences and device compatibility. Research different platforms, read user reviews, and explore their features before making a choice. Are free eBooks of good quality? Yes, many reputable platforms offer high-quality free eBooks, including classics and public domain works. However, make sure to verify the source to ensure the eBook credibility. Can I read eBooks without an eReader? Absolutely! Most eBook platforms offer webbased readers or mobile apps that allow you to read eBooks on your computer, tablet, or smartphone. How do I avoid digital eye strain while reading eBooks? To prevent digital eye strain, take regular breaks, adjust the font size and background color, and ensure proper lighting while reading eBooks. What the advantage of interactive eBooks? Interactive eBooks incorporate multimedia elements, quizzes, and activities, enhancing the reader engagement and providing a more immersive learning experience. Murray 96114002900 Manual is one of the best book in our library for free trial. We provide copy of Murray 96114002900 Manual in digital format, so the resources that you find are reliable. There are also many Ebooks of related with Murray 96114002900 Manual. Where to download Murray 96114002900 Manual online for free? Are you looking for Murray 96114002900 Manual PDF? This is definitely going to save you time and cash in something you should think about. If you trying to find then search around for online. Without a doubt there are numerous these available and many of them have the freedom. However without doubt you receive whatever you purchase. An alternate way to get ideas is always to check another Murray 96114002900 Manual. This method for see exactly what may be included and adopt these ideas to your book. This site will almost certainly help you save time and effort, money and stress. If you are looking for free books then you really should consider finding to assist you try

this. Several of Murray 96114002900 Manual are for sale to free while some are payable. If you arent sure if the books you would like to download works with for usage along with your computer, it is possible to download free trials. The free guides make it easy for someone to free access online library for download books to your device. You can get free download on free trial for lots of books categories. Our library is the biggest of these that have literally hundreds of thousands of different products categories represented. You will also see that there are specific sites catered to different product types or categories, brands or niches related with Murray 96114002900 Manual. So depending on what exactly you are searching, you will be able to choose e books to suit your own need. Need to access completely for Campbell Biology Seventh Edition book? Access Ebook without any digging. And by having access to our ebook online or by storing it on your computer, you have convenient answers with Murray 96114002900 Manual To get started finding Murray 96114002900 Manual, you are right to find our website which has a comprehensive collection of books online. Our library is the biggest of these that have literally hundreds of thousands of different products represented. You will also see that there are specific sites catered to different categories or niches related with Murray 96114002900 Manual So depending on what exactly you are searching, you will be able to choose ebook to suit your own need. Thank you for reading Murray 96114002900 Manual. Maybe you have knowledge that, people have search numerous times for their favorite readings like this Murray 96114002900 Manual, but end up in harmful downloads. Rather than reading a good book with a cup of coffee in the afternoon, instead they juggled with some harmful bugs inside their laptop. Murray 96114002900 Manual is available in our book collection an online access to it is set as public so you can download it instantly. Our digital library spans in multiple locations, allowing you to get the most less latency time to download any of our books like this one. Merely said, Murray 96114002900 Manual is universally compatible with any devices to read.

Find Murray 96114002900 Manual :

[nokia 5800 xpressmusic users guide](#)

[norfolk vision of england](#)

[non medical private duty manual](#)

[nordstrom guide to mens style](#)

[nosler reloading guide 7 publication date](#)

[not suspicious hollywood](#)

[northern united states tree dichotomous key](#)

[non knowledge risk bank company management institutions](#)

[noise control in industry third edition noise control in industry third edition](#)

north-adams-ma-postcard-history-series

not all wives women of colonial philadelphia

nontechnical guide to petroleum geology exploration drilling and production

non verbal learning disabilities non verbal learning disabilities

not quite enough not quite series

not now bernard david mckee

Murray 96114002900 Manual :

Frindle: Summary, Characters & Vocabulary Dec 21, 2021 — Frindle is the story of Nick Allen and his desire to show his teacher Mrs. Granger that words can come from anywhere. Even though Nick is known ... Frindle Summary and Study Guide The novel explores themes about differing adult and student perspectives, actions and their consequences, and the power of language. Clements draws inspiration ... Frindle Chapter 1 Summary When Nick was in third grade, he decided to turn his classroom into a tropical island paradise. First, he asked all of his classmates to make paper palm trees ... Frindle Chapter 1: Nick Summary & Analysis Dec 6, 2018 — Here, he uses Miss Deaver's status as a first-year teacher to trick her into giving her students way more power than the school wants them to ... Frindle - Chapter Summaries - Jackson Local Schools Jackson Memorial Middle School · Raddish, Katie · Frindle - Chapter Summaries. <http://www.enotes.com/topics/> ... Frindle Summary & Study Guide A man in Westfield, Bud Lawrence, sees an opportunity and begins making pens with the word frindle on them. Though local demand dwindles quickly, national and ... Frindle Summary - eNotes.com Sep 12, 2022 — The first chapter of Frindle describes Nick Allen's first acts of creative rebellion. Chapter One tells how he transformed Mrs. Deaver's third- ... Frindle Chapters 1-3 Summary & Analysis In fourth grade, Nick learns that red-wing blackbirds evade their predators by making a chirping sound that is difficult to locate. Nick experiments during ... Frindle Summary Sep 3, 2023 — Nick Allen is a basically good kid with an exceptional imagination. · The following day, Nick raises his hand to tell Mrs Granger that he has ... Frindle Book Summary - Written By Andrew Clements - YouTube Toefl Post Test Belajar Toefl Online Pdf Toefl Post Test Belajar Toefl Online Pdf. INTRODUCTION Toefl Post Test Belajar Toefl Online Pdf [PDF]. Vocabulary for TOEFL iBT. 2007 Provides an overview of ... Contoh Soal TOEFL dan Cara Penyelesaiannya | EF Blog Pada artikel kali ini, kami akan membantu Anda untuk memahami soal dalam tes TOEFL. Berikut adalah salah satu soal dalam tes TOEFL dan tips penyelesaiannya. Simulasi Tes TOEFL Online Gratis Mau skor TOEFL tinggi? Persiapkan dirimu dengan mengikuti simulasi tes TOEFL online gratis di Cakap! At Home Testing for the TOEFL iBT Test Learn what to expect on test day when you take the TOEFL iBT test at home, including the check-in process, interacting with the proctor and troubleshooting ... Jika Anda mengikuti TOEFL iBT Home Edition, atau bagian Paper Edition Speaking, pelajari apa yang diharapkan pada hari tes dan apa

yang harus dilakukan sebelum dan selama ... TOEFL iBT Test Prep Courses Official TOEFL iBT® Prep Course · do in-depth lessons and activities across the 4 skills — Reading, Listening, Speaking and Writing · take pre- and post-tests to ... Kursus Persiapan TOEFL iBT ® Resmi · melakukan pelajaran dan aktivitas mendalam di 4 keterampilan — Membaca, Mendengar, Berbicara, dan Menulis · mengikuti tes sebelum dan sesudah untuk ... Structure TOEFL Pembahasan soal post test 1 - YouTube Soal Test TOEFL Online Interaktif Listening, Reading & ... Soal test TOEFL online sesi listening, reading dan structure and written expression secara interaktif ini bisa diikuti sebelum test toefl itp sesungguhnya. TOEFL iBT Practice Tests and Sets TOEFL iBT® Free Practice Test · View correct answers in the Reading and Listening sections. · Listen to sample Speaking responses. · Read sample Writing responses. Latihan TOEFL® Online... Rasakan bagaimana rasanya mengikuti tes TOEFL iBT yang sebenarnya. ... Anda dapat menghemat tes TOEFL Practice Online dan lebih banyak lagi ketika Anda membeli TOEFL ... Teknik MUDAH dan CEPAT Mengerjakan TOEFL I Post Test ... Website Belajar TOEFL Gratis Jul 14, 2021 — Official Online TOEFL ITP Test · Free Placement Test · Our Alumni · Articles ... Include: Pre-Test, Post-Test; Bonus 4x Kelas Scholarship ... Pay It Forward (2000) A young boy attempts to make the world a better place after his teacher gives him that chance. A young boy attempts to make the world a better place after ... Pay It Forward (film) Pay It Forward is a 2000 American romantic drama film directed by Mimi Leder. The film is based loosely on the novel of the same name by Catherine Ryan Hyde ... Watch Pay It Forward | Prime Video Social studies teacher Eugene Simonet gives his class an assignment: look at the world around you and fix what you don't like. One student comes up with an ... Pay it forward Pay it forward is an expression for describing the beneficiary of a good deed repaying the kindness to others rather than paying it back to the original ... Pay It Forward The story of a social studies teacher who gives an assignment to his junior high school class to think of an idea to change the world for the better, then put ... Pay It Forward by Catherine Ryan Hyde The story of how a boy who believed in the goodness of human nature set out to change the world. Pay It Forward is a wondrous and moving novel about Trevor ... Pay It Forward (2000) Official Trailer - YouTube Pay It Forward: Young Readers Edition - Ebooks - Everand Pay It Forward is a moving, uplifting novel about Trevor McKinney, a twelve-year-old boy in a small California town who accepts his teacher's challenge to earn ... Pay It Forward | Movies Just imagine. You do a favor that really helps someone and tell him or her not to pay it back, but to pay it forward to three other people who, in turn, ... Pay It Forward : Kevin Spacey, Haley ... Run time, 2 hours and 3 minutes. Number of discs, 1. Media Format, Anamorphic, Closed-captioned, Multiple Formats, Dolby, Color, Widescreen, NTSC.