

FOOTSTEP BEARING

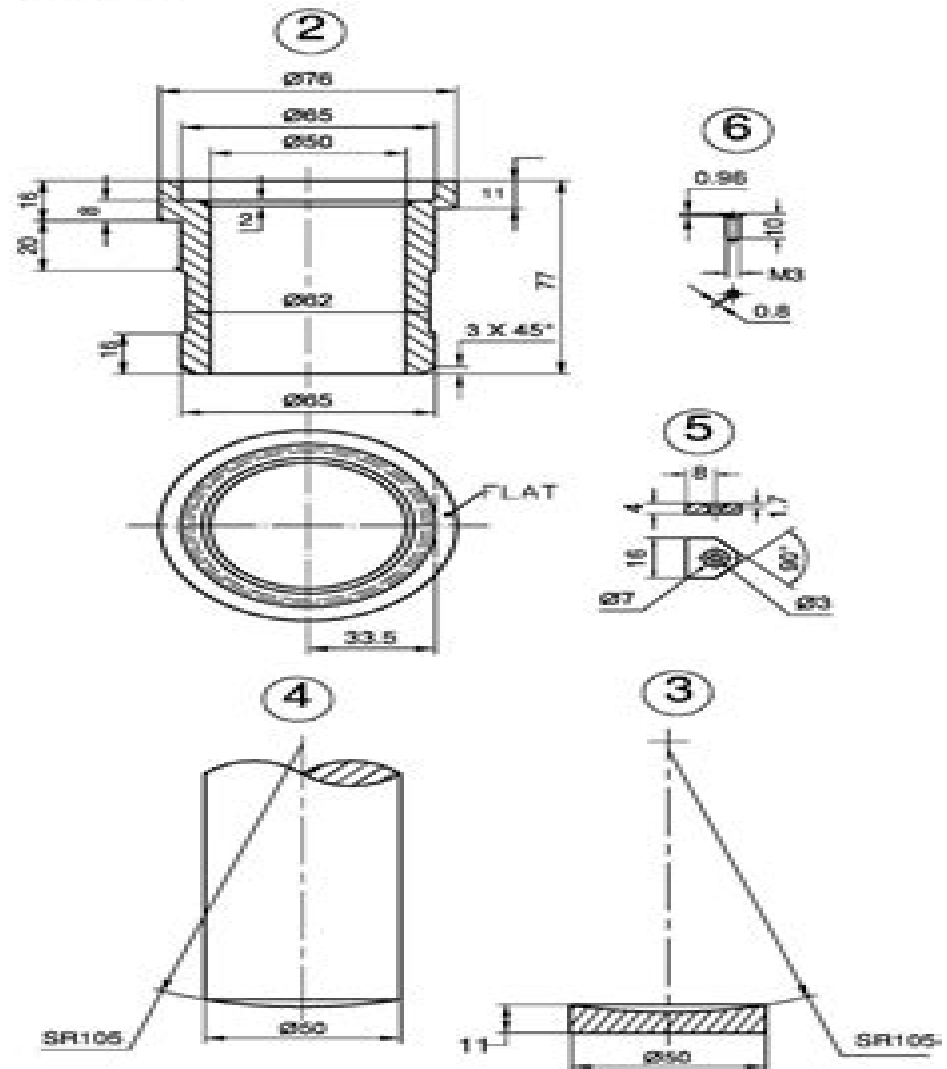
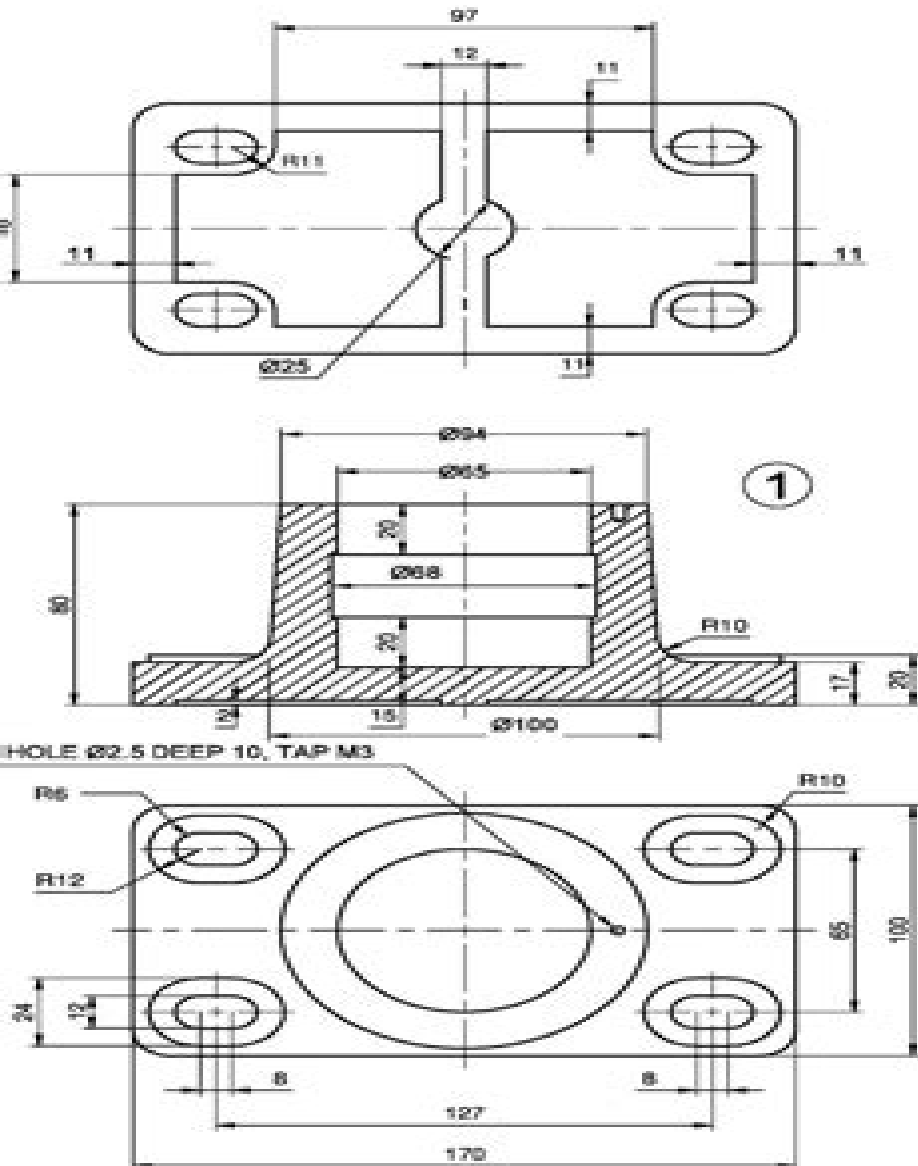

6	SCREW	Fe-410 W	1
5	LOCKING PLATE	Fe-410 W	1
4	SHAFT	Fe-410 W	1
3	PAD	GUN METAL	1
2	BUSH	GUN METAL	1
1	SUPPORTING BRACKET	CAST IRON	1
ITEM NO	DESCRIPTION	MATERIAL	NO OFF

[Pdf Machine Drawing By Gopalakrishnan Free Download](#)

Raffaela Di Napoli



Pdf Machine Drawing By Gopalakrishnan Free Download:

Reviewing **Pdf Machine Drawing By Gopalakrishnan Free Download**: Unlocking the Spellbinding Force of Linguistics

In a fast-paced world fueled by information and interconnectivity, the spellbinding force of linguistics has acquired newfound prominence. Its capacity to evoke emotions, stimulate contemplation, and stimulate metamorphosis is truly astonishing. Within the pages of "**Pdf Machine Drawing By Gopalakrishnan Free Download**," an enthralling opus penned by a highly acclaimed wordsmith, readers embark on an immersive expedition to unravel the intricate significance of language and its indelible imprint on our lives. Throughout this assessment, we shall delve in to the book is central motifs, appraise its distinctive narrative style, and gauge its overarching influence on the minds of its readers.

https://correiodobrasil.blogosfero.cc/public/detail/Download_PDFS/Palfinger_Pc_1300_Manuals.pdf

Table of Contents Pdf Machine Drawing By Gopalakrishnan Free Download

1. Understanding the eBook Pdf Machine Drawing By Gopalakrishnan Free Download
 - The Rise of Digital Reading Pdf Machine Drawing By Gopalakrishnan Free Download
 - Advantages of eBooks Over Traditional Books
2. Identifying Pdf Machine Drawing By Gopalakrishnan Free Download
 - Exploring Different Genres
 - Considering Fiction vs. Non-Fiction
 - Determining Your Reading Goals
3. Choosing the Right eBook Platform
 - Popular eBook Platforms
 - Features to Look for in an Pdf Machine Drawing By Gopalakrishnan Free Download
 - User-Friendly Interface
4. Exploring eBook Recommendations from Pdf Machine Drawing By Gopalakrishnan Free Download
 - Personalized Recommendations
 - Pdf Machine Drawing By Gopalakrishnan Free Download User Reviews and Ratings
 - Pdf Machine Drawing By Gopalakrishnan Free Download and Bestseller Lists

5. Accessing Pdf Machine Drawing By Gopalakrishnan Free Download Free and Paid eBooks
 - Pdf Machine Drawing By Gopalakrishnan Free Download Public Domain eBooks
 - Pdf Machine Drawing By Gopalakrishnan Free Download eBook Subscription Services
 - Pdf Machine Drawing By Gopalakrishnan Free Download Budget-Friendly Options
6. Navigating Pdf Machine Drawing By Gopalakrishnan Free Download eBook Formats
 - ePub, PDF, MOBI, and More
 - Pdf Machine Drawing By Gopalakrishnan Free Download Compatibility with Devices
 - Pdf Machine Drawing By Gopalakrishnan Free Download Enhanced eBook Features
7. Enhancing Your Reading Experience
 - Adjustable Fonts and Text Sizes of Pdf Machine Drawing By Gopalakrishnan Free Download
 - Highlighting and Note-Taking Pdf Machine Drawing By Gopalakrishnan Free Download
 - Interactive Elements Pdf Machine Drawing By Gopalakrishnan Free Download
8. Staying Engaged with Pdf Machine Drawing By Gopalakrishnan Free Download
 - Joining Online Reading Communities
 - Participating in Virtual Book Clubs
 - Following Authors and Publishers Pdf Machine Drawing By Gopalakrishnan Free Download
9. Balancing eBooks and Physical Books Pdf Machine Drawing By Gopalakrishnan Free Download
 - Benefits of a Digital Library
 - Creating a Diverse Reading Collection Pdf Machine Drawing By Gopalakrishnan Free Download
10. Overcoming Reading Challenges
 - Dealing with Digital Eye Strain
 - Minimizing Distractions
 - Managing Screen Time
11. Cultivating a Reading Routine Pdf Machine Drawing By Gopalakrishnan Free Download
 - Setting Reading Goals Pdf Machine Drawing By Gopalakrishnan Free Download
 - Carving Out Dedicated Reading Time
12. Sourcing Reliable Information of Pdf Machine Drawing By Gopalakrishnan Free Download
 - Fact-Checking eBook Content of Pdf Machine Drawing By Gopalakrishnan Free Download
 - Distinguishing Credible Sources
13. Promoting Lifelong Learning

- Utilizing eBooks for Skill Development
- Exploring Educational eBooks

14. Embracing eBook Trends

- Integration of Multimedia Elements
- Interactive and Gamified eBooks

Pdf Machine Drawing By Gopalakrishnan Free Download Introduction

In today's digital age, the availability of Pdf Machine Drawing By Gopalakrishnan Free Download books and manuals for download has revolutionized the way we access information. Gone are the days of physically flipping through pages and carrying heavy textbooks or manuals. With just a few clicks, we can now access a wealth of knowledge from the comfort of our own homes or on the go. This article will explore the advantages of Pdf Machine Drawing By Gopalakrishnan Free Download books and manuals for download, along with some popular platforms that offer these resources. One of the significant advantages of Pdf Machine Drawing By Gopalakrishnan Free Download books and manuals for download is the cost-saving aspect. Traditional books and manuals can be costly, especially if you need to purchase several of them for educational or professional purposes. By accessing Pdf Machine Drawing By Gopalakrishnan Free Download versions, you eliminate the need to spend money on physical copies. This not only saves you money but also reduces the environmental impact associated with book production and transportation. Furthermore, Pdf Machine Drawing By Gopalakrishnan Free Download books and manuals for download are incredibly convenient. With just a computer or smartphone and an internet connection, you can access a vast library of resources on any subject imaginable. Whether you're a student looking for textbooks, a professional seeking industry-specific manuals, or someone interested in self-improvement, these digital resources provide an efficient and accessible means of acquiring knowledge. Moreover, PDF books and manuals offer a range of benefits compared to other digital formats. PDF files are designed to retain their formatting regardless of the device used to open them. This ensures that the content appears exactly as intended by the author, with no loss of formatting or missing graphics. Additionally, PDF files can be easily annotated, bookmarked, and searched for specific terms, making them highly practical for studying or referencing. When it comes to accessing Pdf Machine Drawing By Gopalakrishnan Free Download books and manuals, several platforms offer an extensive collection of resources. One such platform is Project Gutenberg, a nonprofit organization that provides over 60,000 free eBooks. These books are primarily in the public domain, meaning they can be freely distributed and downloaded. Project Gutenberg offers a wide range of classic literature, making it an excellent resource for literature enthusiasts. Another popular platform for Pdf Machine Drawing By Gopalakrishnan Free Download books and manuals is Open Library. Open Library is an initiative of the Internet Archive, a non-profit organization dedicated

to digitizing cultural artifacts and making them accessible to the public. Open Library hosts millions of books, including both public domain works and contemporary titles. It also allows users to borrow digital copies of certain books for a limited period, similar to a library lending system. Additionally, many universities and educational institutions have their own digital libraries that provide free access to PDF books and manuals. These libraries often offer academic texts, research papers, and technical manuals, making them invaluable resources for students and researchers. Some notable examples include MIT OpenCourseWare, which offers free access to course materials from the Massachusetts Institute of Technology, and the Digital Public Library of America, which provides a vast collection of digitized books and historical documents. In conclusion, Pdf Machine Drawing By Gopalakrishnan Free Download books and manuals for download have transformed the way we access information. They provide a cost-effective and convenient means of acquiring knowledge, offering the ability to access a vast library of resources at our fingertips. With platforms like Project Gutenberg, Open Library, and various digital libraries offered by educational institutions, we have access to an ever-expanding collection of books and manuals. Whether for educational, professional, or personal purposes, these digital resources serve as valuable tools for continuous learning and self-improvement. So why not take advantage of the vast world of Pdf Machine Drawing By Gopalakrishnan Free Download books and manuals for download and embark on your journey of knowledge?

FAQs About Pdf Machine Drawing By Gopalakrishnan Free Download Books

What is a Pdf Machine Drawing By Gopalakrishnan Free Download PDF? A PDF (Portable Document Format) is a file format developed by Adobe that preserves the layout and formatting of a document, regardless of the software, hardware, or operating system used to view or print it. **How do I create a Pdf Machine Drawing By Gopalakrishnan Free Download PDF?** There are several ways to create a PDF: Use software like Adobe Acrobat, Microsoft Word, or Google Docs, which often have built-in PDF creation tools. Print to PDF: Many applications and operating systems have a "Print to PDF" option that allows you to save a document as a PDF file instead of printing it on paper. Online converters: There are various online tools that can convert different file types to PDF. **How do I edit a Pdf Machine Drawing By Gopalakrishnan Free Download PDF?** Editing a PDF can be done with software like Adobe Acrobat, which allows direct editing of text, images, and other elements within the PDF. Some free tools, like PDFescape or Smallpdf, also offer basic editing capabilities. **How do I convert a Pdf Machine Drawing By Gopalakrishnan Free Download PDF to another file format?** There are multiple ways to convert a PDF to another format: Use online converters like Smallpdf, Zamzar, or Adobe Acrobats export feature to convert PDFs to formats like Word, Excel, JPEG, etc. Software like Adobe Acrobat, Microsoft Word, or other PDF editors may have options to export or save PDFs in different formats. **How do I password-protect a Pdf Machine Drawing By**

Gopalakrishnan Free Download PDF? Most PDF editing software allows you to add password protection. In Adobe Acrobat, for instance, you can go to "File" -> "Properties" -> "Security" to set a password to restrict access or editing capabilities. Are there any free alternatives to Adobe Acrobat for working with PDFs? Yes, there are many free alternatives for working with PDFs, such as: LibreOffice: Offers PDF editing features. PDFsam: Allows splitting, merging, and editing PDFs. Foxit Reader: Provides basic PDF viewing and editing capabilities. How do I compress a PDF file? You can use online tools like Smallpdf, ILovePDF, or desktop software like Adobe Acrobat to compress PDF files without significant quality loss. Compression reduces the file size, making it easier to share and download. Can I fill out forms in a PDF file? Yes, most PDF viewers/editors like Adobe Acrobat, Preview (on Mac), or various online tools allow you to fill out forms in PDF files by selecting text fields and entering information. Are there any restrictions when working with PDFs? Some PDFs might have restrictions set by their creator, such as password protection, editing restrictions, or print restrictions. Breaking these restrictions might require specific software or tools, which may or may not be legal depending on the circumstances and local laws.

Find Pdf Machine Drawing By Gopalakrishnan Free Download :

[palfinger pc 1300 manuals](#)

[pals provider manual](#)

panasonic camera manuals online

panasonic dmr ex75 ex85 service manual repair guide

panasonic hc v500 hd camera service manual

panasonic ag hmc70 hmc71 hmc72 hmc73 hmc74 service manual and repair guide

panasonic surround sound manuals

panasonic lumix dmc lz1 lz2 series service manual repair guide

[pakistan main bahan ki phudi mari](#)

[palo alto firewall admin guide](#)

~~panasonic lumix dmc sz1 sz02 series service manual repair guide~~

[palladio and his legacy a transatlantic journey](#)

panasonic 24 ghz digital gigarange manual

[panasonic manuals nz](#)

paleo lunchbox busy peoples cookbook for quick easy and portable meals

Pdf Machine Drawing By Gopalakrishnan Free Download :

outline for obesity research paper 1004 words bartleby - Mar 28 2022

web introduction hook obesity is a medical problem and not just a physical appearance flaw kidshealth org tell the reader what to expect obesity is clearly associated with increased morbidity and mortality nih publications thesis obesity is the cause of many medical problems and complications and needs to be stopped not accepted

obesity in children and adolescents epidemiology causes - Dec 05 2022

web summary this review describes current knowledge on the epidemiology and causes of child and adolescent obesity considerations for assessment and current management approaches before the covid 19 pandemic obesity prevalence in children and adolescents had plateaued in many high income countries despite levels of severe

obesity articles the new england journal of medicine - Jun 30 2022

web oct 5 2023 browse obesity filter showing 1 20 of 679 results newest original article vol 389 no 14 oct 05 2023 global effect of modifiable risk factors on cardiovascular disease and mortality the

a systematic literature review on obesity sciencedirect - Jul 12 2023

web sep 1 2021 the present study conducted a systematic literature review to examine obesity research and machine learning techniques for the prevention and treatment of obesity from 2010 to 2020 accordingly 93 papers are identified from the review articles as primary studies from an initial pool of over 700 papers addressing obesity

obesity research paper with outline gudwriter com - Oct 15 2023

web jun 18 2018 the bmi measure applies to all sexes and ages it should be considered a rough guide that can enable one to know when they are at risk of obesity this paper focuses on obesity as the main cause of health problems in the modern world overview obesity is regarded as one of the leading causes of death across the world compared to

pdf revised outline for childhood obesity part3 researchgate - Apr 28 2022

web oct 16 2016 revised outline for childhood obesity part3 october 2016 project i drew various objects and shapes on a piece of paper that was what my research entailed view project project

obesity research paper research paper examples - Aug 01 2022

web definition obesity is most simply defined as an excess of adipose fat tissue usually with negative health effects however this definition is problematic medically as discussed below the science of obesity is increasingly suggesting that many people can be both obese and healthy

the lived experience of people with obesity study protocol for a - Feb 07 2023

web published 21 june 2021 the lived experience of people with obesity study protocol for a systematic review and synthesis of qualitative studies emma farrell marta bustillo carel w le roux joe nadglowski eva hollmann deirdre mcgillicuddy

systematic reviews 10 article number 181 2021 cite this article 5066 accesses 9 altmetric

obesity and overweight probing causes consequences and - Jun 11 2023

web feb 8 2023 abstract abstract as the worldwide prevalence of overweight and obesity continues to rise so too does the urgency to fully understand mediating mechanisms to discover new targets for safe and effective therapeutic intervention and to identify biomarkers to track obesity and the success of weight loss interventions

[the epidemiology of obesity a big picture pmc national](#) - Jan 06 2023

web obesity greatly increases risk of chronic disease morbidity namely disability depression type 2 diabetes cardiovascular disease certain cancers and mortality childhood obesity results in the same conditions with premature onset or with greater likelihood in adulthood

childhood obesity research paper outline 1291 words - Feb 24 2022

web childhood obesity research paper outline view writing issues filter results travis dwyer topic childhood obesity take care of your body it s the only place you have to live jim rohn there are so many prevalent health

pdf the causes of obesity an in depth review researchgate - May 10 2023

web jul 3 2020 this was in line with research conducted by kim and shin which found a higher prevalence of obesity in males compared to 11 females but a study in turkey using mathematical model analysis about

a systematic literature review on obesity understanding the - Apr 09 2023

web the present study conducted a systematic literature review to examine obesity research and machine learning techniques for the prevention and treatment of obesity from 2010 to 2020 accordingly 93 papers are identified from the review articles as primary studies from an initial pool of over 700 papers addressing obesity

80 obesity research paper topics 2023 updated essaywriter - Sep 02 2022

web jun 15 2023 list of obesity research paper topics 15 ideas of worldwide concern genetics is the leading cause of excessive weight possibility of fatness prediction based on acquired genes environmental correlates of excessive weight rates of overweight people due to fast food chains gender and obesity

obesity research nhlbi nih - Nov 04 2022

web mar 24 2022 obesity research español in this article nhlbi research that really made a difference current research funded by the nhlbi obesity research labs at the nhlbi related obesity programs and guidelines explore more nhlbi research on overweight and obesity

pdf a systematic literature review on obesity researchgate - Mar 08 2023

web aug 1 2021 elankovan sundararajan universiti kebangsaan malaysia maha driss prince sultan university wadii boulila prince sultan university abstract and figures obesity is considered a principal

[obesity risk factors complications and strategies for](#) - Aug 13 2023

web oct 12 2017 obesity is associated with a range of comorbidities including diabetes cardiovascular disease obstructive sleep apnea and cancer however modest weight loss in the 5 10 range and above can significantly improve health related outcomes

how to write a strong obesity research paper - Sep 14 2023

web mar 27 2023 updated 3 27 2023 table of contents basic guidelines on obesity research paper how to write an obesity thesis statement 20 top notch obesity research paper topics best sample of obesity research paper outline specifics of childhood obesity research paper top 20 childhood obesity research paper topics childhood

how to write a research paper on obesity perfectessay - Oct 03 2022

web aug 8 2017 the essay on obesity is a 5 paragraph essay that seeks to address what the community can do to combat obesity in the country introduction a hook a quote statistics b some statistics on obesity c who is affected d why we need to combat this epidemic e thesis statement body paragraph 1

obesity research paper pdf obesity junk food scribd - May 30 2022

web 16 february 2006 obesity in america in the united states today obesity has become an enormous problem in the last 3 decades the number of people overweight has increased dramatically a study done by the centers of disease control showed that since 1980 one third of our adult population has become overweight

the handmaid and the carpenter a novel berg elizabeth - Sep 21 2023

web the handmaid and the carpenter a novel item preview remove circle share or embed this item english access restricted item true addeddate 2011 09 16 16 58 14

the handmaid and the carpenter on apple books - May 05 2022

web the handmaid and the carpenter a novel author elizabeth berg summary a new rendition of the christmas story follows a young couple mary and joseph who are

the handmaid and the carpenter by elizabeth berg - May 17 2023

web the handmaid and the carpenter by elizabeth berg 2006 random house edition in english 1st ed

the handmaid and the carpenter a novel amazon com - Jan 13 2023

web the handmaid and the carpenter by elizabeth berg 2006 random house publishing group edition electronic resource in english

the handmaid and the carpenter 2006 edition open library - Oct 10 2022

web handmaid and the carpenter by elizabeth berg 2008 random house publishing group edition in english it looks like you re offline donate Čestina cs handmaid and

amazon com customer reviews the handmaid and the - Apr 04 2022

web discover and share books you love on goodreads

the handmaid and the carpenter a novel - Jun 18 2023

web in this wonderful novel about love and trust hope and belief elizabeth berg the bestselling author of we are all welcome here and the year of pleasures transports us to

the handmaid and the carpenter a novel google books - Jul 19 2023

web oct 28 2008 elizabeth berg random house publishing group oct 28 2008 fiction 176 pages this wonderful novel

transports us to nazareth in biblical times where we

the handmaid and the carpenter a novel kindle edition - Nov 30 2021

[the handmaid and the carpenter a novel google books](#) - Apr 16 2023

web audible audiobook unabridged in this wonderful novel about love and trust hope and belief elizabeth berg the best selling author of we are all welcome here and the year

the handmaid and the carpenter a novel amazon co uk - Jun 06 2022

web a novel about love and trust hope and belief elizabeth berg invites us to reimagine the events of the classic christmas story mary and joseph meet become betrothed and

handmaid and the carpenter 2008 edition open library - Jul 07 2022

web dec 8 2022 elizabeth berg s the handmaid and the carpenter a novel is a richly detailed saga of an historic time and a biblical couple it is a tale that she has imbued

loading interface goodreads - Jan 01 2022

the handmaid and the carpenter by elizabeth berg open library - Oct 30 2021

the handmaid and the carpenter a novel kindle edition - Aug 20 2023

web bibtext endnote refman in this wonderful novel about love and trust hope and belief elizabeth berg the bestselling author of we are all welcome here and the year of

the handmaid and the carpenter 2006 edition open library - Sep 09 2022

web buy the handmaid and the carpenter a novel by berg elizabeth isbn 9781400065387 from amazon s book store everyday low prices and free delivery on

[the handmaid and the carpenter penguin random house](#) - Dec 12 2022

web the handmaid and the carpenter by elizabeth berg 2006 wheeler pub edition in english

the handmaid and the carpenter by elizabeth berg open library - Feb 14 2023

web nov 7 2006 exquisitely written and imbued with the truthful emotions and richness of detail that have earned elizabeth berg a devoted readership the handmaid and the

the handmaid and the carpenter a novel worldcat org - Feb 02 2022

web the handmaid and the carpenter by elizabeth berg 2007 random house edition in english 1st ed

the handmaid and the carpenter a novel worldcat org - Mar 03 2022

web exquisitely written and imbued with the truthful emotions and richness of detail that have earned elizabeth berg a devoted readership the handmaid and the carpenter

the handmaid and the carpenter a novel hardcover - Aug 08 2022

web nov 7 2006 a novel elizabeth berg 4 0 7 ratings 8 99 publisher description in this wonderful novel about love and trust hope and belief elizabeth berg the bestselling

the handmaid and the carpenter a novel google books - Mar 15 2023

web the handmaid and the carpenter by elizabeth berg 9780345505910 penguinrandomhouse com books this wonderful novel transports us to nazareth in

the handmaid and the carpenter a novel barnes noble - Nov 11 2022

web abebooks com the handmaid and the carpenter a novel 9781400065387 by berg elizabeth and a great selection of similar new used and collectible books available now

agpt situational judgement test preparation 2022 opendoors - Apr 11 2023

web agpt situational judgement test preparation 3 3 epoch used the technical means available to produce maximum illusion he discusses frescoes such as those in the villa dei misteri in pompeii and the gardens

agpt situational judgement test preparation sibole online - Nov 06 2022

web to get started finding agpt situational judgement test preparation you are right to find our website which has a comprehensive collection of manuals listed our library is the biggest of these that have literally hundreds of thousands of different products represented

situational judgement test oxford assess and progress 2nd - Feb 26 2022

web fsot test prep and practice questions for the foreign service officer test 2nd edition cognitive assessment for clinicians the dental foundation interview guide with situational judgement tests offers an indispensable step by step guide to the dental foundation training application process explains the

agptsituationaljudgementtestpreparation apps newfounding - Dec 07 2022

web situational judgment tests advances the science and practice of sjts by promoting a theoretical framework providing an understanding of best practices and establishing a research agenda for years to come currently there is no other source that provides such a comprehensive treatment of situational judgment testing

royal australian college of general practitioners racgp - Sep 04 2022

web aug 2 2022 there are three main phases in the racgp agpt selection process one of which is undertaking the candidate assessment and applied knowledge test caakt the caakt consists of two types of questions knowledge test questions and situational judgement test questions

situational judgement test 15 free tests 100 questions - Aug 03 2022

web jun 14 2022 situational judgement tests assess your ability to deal with a variety of common workplace challenges with every question you answer employers will be examining your communication and teamwork skills and how creative or analytical your thinking is throughout the test you ll be faced with different scenarios and asked to pick

free situational judgement tests preparation and example - May 12 2023

web they make it ever so simple to understand every aspect of situational judgement tests which otherwise are so challenging to grasp this guide includes useful tips to pass the test abilities which are required as well as other points which ought to be kept in mind

practice aptitude tests - Apr 30 2022

web recruiting talent our partner picked makes it simple to assess your candidates quickly and accurately find out more

situational judgement test oxford assess and progress 2nd - Jan 28 2022

web organization situational judgement test wikipediasituational judgement test situational judgement tests assess your ability at solving problems in work related situations try these five practice questions designed to be similar to those used by major graduate employers situational judgement tests 5 free questions

pass the situational judgement test by cameron b green copy - Dec 27 2021

web pass the situational judgement test by cameron b green sjt pass the situational judgement test a guide preparing for the civil service judgement test gov uk police situational judgement test sjt preparation 2020 situational judgement test the definitive guide bemo academic consulting everything you need to know

ukcat kursu ukcat Özel ders ukcat İstanbul - Oct 05 2022

web situational judgement ukcat kursu adayların durumlardaki cevaplarını ve tıbbi etiği kavrayışlarını ölçer sınavın bu bölümü 20 senaryo ile ilgili 69 soru içerir ve 27 dakika uzunluğundadır

agpt situational judgement test preparation 2023 - Jul 14 2023

web agpt situational judgement test preparation the situational judgement test at a glance oct 28 2022 the situational

judgement test at a glance provides a sound introduction to the sjt and details ways you can prepare before the assessment it includes worked case examples based on real life scenarios

pdf agpt situational judgement test preparation - Jun 13 2023

web test performance dec 12 2020 situational judgement test mar 27 2022 this timely volume offers a definitive guide to the situational judgement test sjt with over 250 practice questions and all the advice necessary for exam success situational judgment tests nov 03 2022 situational judgment tests advances the science and practice of

agpt situational judgement test preparation copy test the lyst - Jul 02 2022

web agpt situational judgement test preparation 1 agpt situational judgement test preparation eventually you will entirely discover a supplementary experience and realization by spending more cash still when attain you how to that you require to get those all needs later than having significantly

agpt situational judgement test preparation speakings gestamp - Jun 01 2022

web jun 15 2023 about agpt situational judgement test preparation and how to guide agpt situational judgement test preparation that categorized in agpt situational judgement test preparation agpt situational judgement test preparation ebooks agpt situational judgement test preparation is available on pdf epub and doc format

agpt situational judgement test preparation sam arab travelers - Jan 08 2023

web free situational judgement test prep tips 10 questions free agpt situational judgement test preparation sjt bmj on examination situational judgement tests free online practice tests agpt situational judgement test preparation sample questions situational reasoning test free practice tests agpt situational

agpt situational judgement test preparation - Feb 09 2023

web 2 agpt situational judgement test preparation 2019 08 02 hiring process for the job situational judgement test sjt online practice practice 4 mesituational judgement test preparation may not be easy but it is necessary how important is the situational judgement test score for my evaluation

situational judgement free aptitude tests at aptitude test com - Mar 30 2022

web introduction about this test consists of 5 situational judgement scenarios you have 10 minutes to complete the test when you are ready click begin to start the test loading questions

agpt situational judgement test preparation pdf 2023 - Mar 10 2023

web agpt situational judgement test preparation pdf recognizing the artifice ways to get this books agpt situational judgement test preparation pdf is additionally useful you have remained in right site to begin getting this info acquire the agpt situational judgement test preparation pdf associate that we give here and check out the link

caakt tips general practice registrars australia - Aug 15 2023

web may 25 2021 knowledge test kt questions 60 questions situational judgement test sjt questions 20 questions in order to be preparing for the caakt the racgp recommend familiarising yourself with their five domains of general practice if in doubt refer back to these five domains