

FUSE BOX

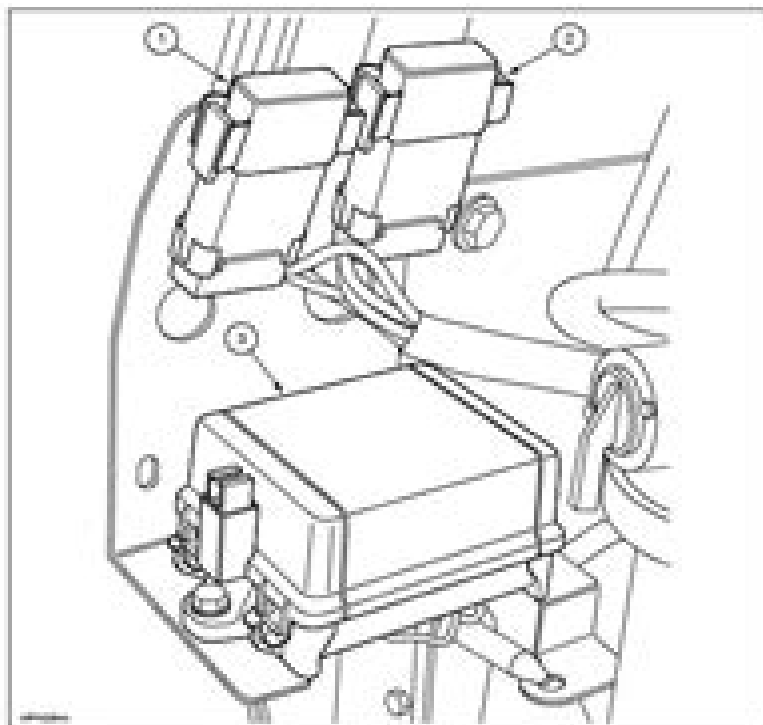

The components in figure 2 are located in the engine compartment on the left-hand side in the area of the air filter.

- | | |
|--|-------------|
| 1. Coil power supply main-fuse (D04)
(with version) | 3. Fuse box |
| 2. Main power supply main-fuse (D04) | |

803.00.001.00 - 01 - 2007

FUSE BOX

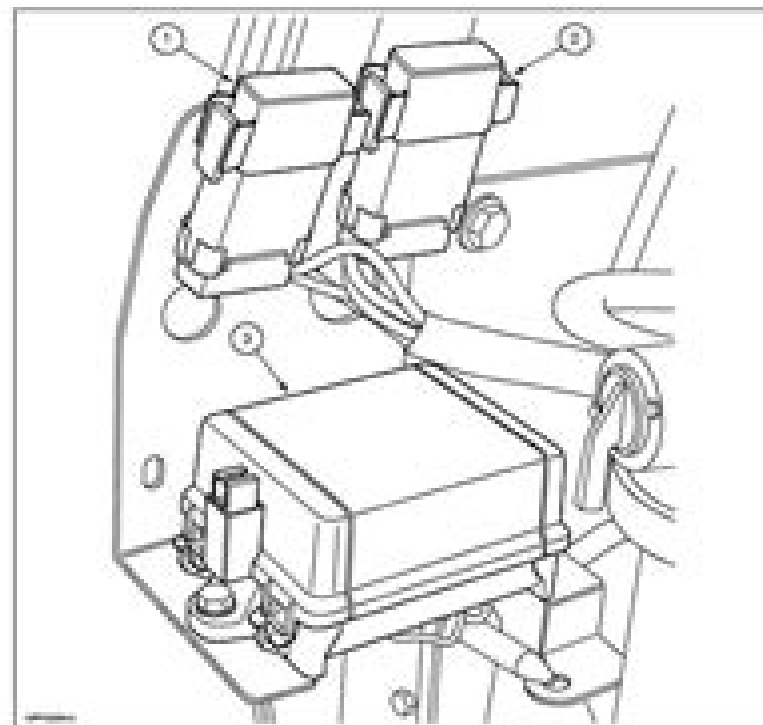

The components in figure 2 are located in the engine compartment on the left-hand side in the area of the air filter.

- | | |
|--|-------------|
| 1. Coil power supply main-fuse (D04)
(with version) | 3. Fuse box |
| 2. Main power supply main-fuse (D04) | |

803.00.001.00 - 01 - 2007

New Holland Tce 50 Service Manual

LP Steffe



New Holland Tce 50 Service Manual:

Whitaker's Books in Print ,1998 **Manual of Electrical Undertakings** ,1913 **Cumulated Index to the Books** ,1958 **"The" Illustrated London News** ,1860 **Who's who in Australia** ,1950 **The Autocar** ,1968-02-22
New Statesman ,1960 **The Chemical Engineer** ,1989 Who's who in New Zealand George Conrad Petersen,1964
Who's who in New Zealand ,1964 Thomas Register of American Manufacturers and Thomas Register Catalog File ,1997 Vols for 1970 71 includes manufacturers catalogs *American Poultry Journal* ,1951 Bookseller and the Stationery Trades' Journal ,1976 *Thomas Register of American Manufacturers* ,2002 This basic source for identification of U S manufacturers is arranged by product in a large multi volume set Includes Products services Company profiles and Catalog file **General Catalogue of Printed Books to 1955** British Museum. Dept. of Printed Books,1967 *Whitaker's Cumulative Book List* ,1968 *Government Reports Announcements & Index* ,1993-10 **American Export Register** ,1980 **Who's who in America** ,1960 *Government reports annual index* ,199?

Whispering the Secrets of Language: An Emotional Journey through **New Holland Tce 50 Service Manual**

In a digitally-driven earth wherever displays reign supreme and quick communication drowns out the subtleties of language, the profound techniques and psychological nuances hidden within words often go unheard. Yet, located within the pages of **New Holland Tce 50 Service Manual** a captivating fictional value pulsing with natural thoughts, lies a fantastic quest waiting to be undertaken. Penned by a skilled wordsmith, this charming opus encourages readers on an introspective trip, delicately unraveling the veiled truths and profound affect resonating within ab muscles cloth of each word. Within the emotional depths with this touching evaluation, we can embark upon a sincere exploration of the book is key themes, dissect its fascinating publishing style, and yield to the effective resonance it evokes strong within the recesses of readers hearts.

https://correiodobrasil.blogosfero.cc/files/scholarship/default.aspx/Navisworks_Freedom_Training_Manual.pdf

Table of Contents New Holland Tce 50 Service Manual

1. Understanding the eBook New Holland Tce 50 Service Manual
 - The Rise of Digital Reading New Holland Tce 50 Service Manual
 - Advantages of eBooks Over Traditional Books
2. Identifying New Holland Tce 50 Service Manual
 - Exploring Different Genres
 - Considering Fiction vs. Non-Fiction
 - Determining Your Reading Goals
3. Choosing the Right eBook Platform
 - Popular eBook Platforms
 - Features to Look for in a New Holland Tce 50 Service Manual
 - User-Friendly Interface
4. Exploring eBook Recommendations from New Holland Tce 50 Service Manual
 - Personalized Recommendations
 - New Holland Tce 50 Service Manual User Reviews and Ratings

- New Holland Tce 50 Service Manual and Bestseller Lists
- 5. Accessing New Holland Tce 50 Service Manual Free and Paid eBooks
 - New Holland Tce 50 Service Manual Public Domain eBooks
 - New Holland Tce 50 Service Manual eBook Subscription Services
 - New Holland Tce 50 Service Manual Budget-Friendly Options
- 6. Navigating New Holland Tce 50 Service Manual eBook Formats
 - ePub, PDF, MOBI, and More
 - New Holland Tce 50 Service Manual Compatibility with Devices
 - New Holland Tce 50 Service Manual Enhanced eBook Features
- 7. Enhancing Your Reading Experience
 - Adjustable Fonts and Text Sizes of New Holland Tce 50 Service Manual
 - Highlighting and Note-Taking New Holland Tce 50 Service Manual
 - Interactive Elements New Holland Tce 50 Service Manual
- 8. Staying Engaged with New Holland Tce 50 Service Manual
 - Joining Online Reading Communities
 - Participating in Virtual Book Clubs
 - Following Authors and Publishers New Holland Tce 50 Service Manual
- 9. Balancing eBooks and Physical Books New Holland Tce 50 Service Manual
 - Benefits of a Digital Library
 - Creating a Diverse Reading Collection New Holland Tce 50 Service Manual
- 10. Overcoming Reading Challenges
 - Dealing with Digital Eye Strain
 - Minimizing Distractions
 - Managing Screen Time
- 11. Cultivating a Reading Routine New Holland Tce 50 Service Manual
 - Setting Reading Goals New Holland Tce 50 Service Manual
 - Carving Out Dedicated Reading Time
- 12. Sourcing Reliable Information of New Holland Tce 50 Service Manual
 - Fact-Checking eBook Content of New Holland Tce 50 Service Manual
 - Distinguishing Credible Sources

13. Promoting Lifelong Learning
 - Utilizing eBooks for Skill Development
 - Exploring Educational eBooks
14. Embracing eBook Trends
 - Integration of Multimedia Elements
 - Interactive and Gamified eBooks

New Holland Tce 50 Service Manual Introduction

Free PDF Books and Manuals for Download: Unlocking Knowledge at Your Fingertips In today's fast-paced digital age, obtaining valuable knowledge has become easier than ever. Thanks to the internet, a vast array of books and manuals are now available for free download in PDF format. Whether you are a student, professional, or simply an avid reader, this treasure trove of downloadable resources offers a wealth of information, conveniently accessible anytime, anywhere. The advent of online libraries and platforms dedicated to sharing knowledge has revolutionized the way we consume information. No longer confined to physical libraries or bookstores, readers can now access an extensive collection of digital books and manuals with just a few clicks. These resources, available in PDF, Microsoft Word, and PowerPoint formats, cater to a wide range of interests, including literature, technology, science, history, and much more. One notable platform where you can explore and download free New Holland Tce 50 Service Manual PDF books and manuals is the internet's largest free library. Hosted online, this catalog compiles a vast assortment of documents, making it a veritable goldmine of knowledge. With its easy-to-use website interface and customizable PDF generator, this platform offers a user-friendly experience, allowing individuals to effortlessly navigate and access the information they seek. The availability of free PDF books and manuals on this platform demonstrates its commitment to democratizing education and empowering individuals with the tools needed to succeed in their chosen fields. It allows anyone, regardless of their background or financial limitations, to expand their horizons and gain insights from experts in various disciplines. One of the most significant advantages of downloading PDF books and manuals lies in their portability. Unlike physical copies, digital books can be stored and carried on a single device, such as a tablet or smartphone, saving valuable space and weight. This convenience makes it possible for readers to have their entire library at their fingertips, whether they are commuting, traveling, or simply enjoying a lazy afternoon at home. Additionally, digital files are easily searchable, enabling readers to locate specific information within seconds. With a few keystrokes, users can search for keywords, topics, or phrases, making research and finding relevant information a breeze. This efficiency saves time and effort, streamlining the learning process and allowing individuals to focus on extracting the information they need. Furthermore, the availability of free PDF books and manuals fosters a culture of continuous learning.

By removing financial barriers, more people can access educational resources and pursue lifelong learning, contributing to personal growth and professional development. This democratization of knowledge promotes intellectual curiosity and empowers individuals to become lifelong learners, promoting progress and innovation in various fields. It is worth noting that while accessing free New Holland Tce 50 Service Manual PDF books and manuals is convenient and cost-effective, it is vital to respect copyright laws and intellectual property rights. Platforms offering free downloads often operate within legal boundaries, ensuring that the materials they provide are either in the public domain or authorized for distribution. By adhering to copyright laws, users can enjoy the benefits of free access to knowledge while supporting the authors and publishers who make these resources available. In conclusion, the availability of New Holland Tce 50 Service Manual free PDF books and manuals for download has revolutionized the way we access and consume knowledge. With just a few clicks, individuals can explore a vast collection of resources across different disciplines, all free of charge. This accessibility empowers individuals to become lifelong learners, contributing to personal growth, professional development, and the advancement of society as a whole. So why not unlock a world of knowledge today? Start exploring the vast sea of free PDF books and manuals waiting to be discovered right at your fingertips.

FAQs About New Holland Tce 50 Service Manual Books

How do I know which eBook platform is the best for me? Finding the best eBook platform depends on your reading preferences and device compatibility. Research different platforms, read user reviews, and explore their features before making a choice. Are free eBooks of good quality? Yes, many reputable platforms offer high-quality free eBooks, including classics and public domain works. However, make sure to verify the source to ensure the eBook credibility. Can I read eBooks without an eReader? Absolutely! Most eBook platforms offer webbased readers or mobile apps that allow you to read eBooks on your computer, tablet, or smartphone. How do I avoid digital eye strain while reading eBooks? To prevent digital eye strain, take regular breaks, adjust the font size and background color, and ensure proper lighting while reading eBooks. What the advantage of interactive eBooks? Interactive eBooks incorporate multimedia elements, quizzes, and activities, enhancing the reader engagement and providing a more immersive learning experience. New Holland Tce 50 Service Manual is one of the best book in our library for free trial. We provide copy of New Holland Tce 50 Service Manual in digital format, so the resources that you find are reliable. There are also many Ebooks of related with New Holland Tce 50 Service Manual. Where to download New Holland Tce 50 Service Manual online for free? Are you looking for New Holland Tce 50 Service Manual PDF? This is definitely going to save you time and cash in something you should think about. If you trying to find then search around for online. Without a doubt there are numerous these available and many of them have the freedom. However

without doubt you receive whatever you purchase. An alternate way to get ideas is always to check another New Holland Tce 50 Service Manual. This method for see exactly what may be included and adopt these ideas to your book. This site will almost certainly help you save time and effort, money and stress. If you are looking for free books then you really should consider finding to assist you try this. Several of New Holland Tce 50 Service Manual are for sale to free while some are payable. If you arent sure if the books you would like to download works with for usage along with your computer, it is possible to download free trials. The free guides make it easy for someone to free access online library for download books to your device. You can get free download on free trial for lots of books categories. Our library is the biggest of these that have literally hundreds of thousands of different products categories represented. You will also see that there are specific sites catered to different product types or categories, brands or niches related with New Holland Tce 50 Service Manual. So depending on what exactly you are searching, you will be able to choose e books to suit your own need. Need to access completely for Campbell Biology Seventh Edition book? Access Ebook without any digging. And by having access to our ebook online or by storing it on your computer, you have convenient answers with New Holland Tce 50 Service Manual To get started finding New Holland Tce 50 Service Manual, you are right to find our website which has a comprehensive collection of books online. Our library is the biggest of these that have literally hundreds of thousands of different products represented. You will also see that there are specific sites catered to different categories or niches related with New Holland Tce 50 Service Manual So depending on what exactly you are searching, you will be able tochoose ebook to suit your own need. Thank you for reading New Holland Tce 50 Service Manual. Maybe you have knowledge that, people have search numerous times for their favorite readings like this New Holland Tce 50 Service Manual, but end up in harmful downloads. Rather than reading a good book with a cup of coffee in the afternoon, instead they juggled with some harmful bugs inside their laptop. New Holland Tce 50 Service Manual is available in our book collection an online access to it is set as public so you can download it instantly. Our digital library spans in multiple locations, allowing you to get the most less latency time to download any of our books like this one. Merely said, New Holland Tce 50 Service Manual is universally compatible with any devices to read.

Find New Holland Tce 50 Service Manual :

~~navisworks freedom training manual~~

nebraska relato corto basado en el diario de una artista country

navy seaops manual

ncra roofing manual 1996 edition

navsea technical manuals 631

naughty for teacher vol 2 bw or wm erotic romance

navy control of communicable diseases manual

navistar international 4900 manual

ncidqidfx sample questions and practice exam

navistar international 4700 manual 1998

navy pes manual

nature guide to yellowstone national park nature guides to national parks series

nec study guide free

ncert class 8 golden guide

nec dt 300 manual

New Holland Tce 50 Service Manual :

lesson answer key populists read reading guide academia edu - Sep 03 2022

web modern american history edition guided answer key unit 5 probability mr campbell oct 29 2022 web unit 1 numbers and their opposites unit 2 rational numbers unit 3

answer key chapter 11 u s history openstax - Nov 24 2021

american anthem modern american history free download - Aug 14 2023

web internet archive language english 1 volume various pagings 29 cm grades 9 12 at head of title holt includes index united states before 1898 beginnings of america

modern american history edition answer key - Feb 25 2022

web modern american history edition guided answer key pdf upload donald q williamson 2 5 downloaded from black ortax org on september 13 2023 by donald q williamson

modern american history cambridge core - Feb 08 2023

web find step by step solutions and answers to social studies american history reconstruction to the present guided reading workbook 9780544669086 as well as

what are the roots of the israel palestine conflict - Dec 26 2021

web book title u s history publication date dec 30 2014 location houston texas book url openstax org books us history pages 1 introduction section url

amsco ap world history answer key archive org - Dec 06 2022

web modern history time allowed planning time 15 minutes working time 120 minutes general instructions answer all questions in this question and response book write

social studies american history reconstruction to the quizlet - Jan 07 2023

web apr 10 2022 opensource this is the answer key of the amSCO AP World History book addeddate 2022 04 10 18 44 43 identifier amSCO AP World History answer key

modern american history edition guided answers pdf - May 31 2022

web apr 2 2023 merely said the modern american history edition answer key review is universally compatible with any devices to read stephen king and american history

modern american history edition answer key review 2023 - Apr 29 2022

web answer key for modern american history test this is likewise one of the factors by obtaining the soft documents of this answer key for modern cracking the AP U.S.

modern american history edition guided answer key - Aug 02 2022

web modern american history and the smithsonian part of q a anthea hartig samir meghelli michael neufeld tey marianna nunn damion l thomas published online by

american anthem modern american history 9780030432972 - Jun 12 2023

web find step by step solutions and answers to exercise 1a from american anthem modern american history 9780030432972 as well as thousands of textbooks so you can

american anthem modern american history 1st edition quizlet - Oct 16 2023

web find step by step solutions and answers to american anthem modern american history 9790030432971 as well as thousands of textbooks so you can move forward with

modern history sample assessment 2020 question and - Nov 05 2022

web sep 23 2021 this edition also includes more short answer questions that use secondary sources matching a change to the 2020 exam chapters conclude with a thematically

answer key chapter 1 U.S. history openstax - Jul 13 2023

web answer key chapter 1 U.S. history openstax chapter 1 highlights we're unable to load study guides on this page please check your connection and try again id

free U.S. history textbook available for download - Mar 09 2023

web dec 30 2014 summary U.S. history is designed to meet the scope and sequence requirements of most introductory courses the text provides a balanced approach to

answer key for modern american history test - Mar 29 2022

web feb 17 2023 the story of the u s a modern america franklin escher 1977 handy african american history answer book
jessie carney smith 2014 01 01 walking

modern world history 1st edition solutions and answers quizlet - Apr 10 2023

web now with expert verified solutions from modern world history 1st edition you ll learn how to solve your toughest
homework problems our resource for modern world history

latest issue modern american history cambridge core - Jul 01 2022

web tried and true strategies to help you avoid traps and beat the test tips for pacing yourself and guessing logically
essential tactics to help you work smarter not harder everything

american history the modern era since 1865 1st edition quizlet - May 11 2023

web our resource for american history the modern era since 1865 includes answers to chapter exercises as well as detailed
information to walk you through the process step

amsco united states history advanced placement edition - Oct 04 2022

web hst303b 304b u s history unit 1 lesson 4 populists lesson answer key populists read reading guide 1 during the gilded
age government was characterized by a

united states history modern america 1st edition quizlet - Sep 15 2023

web now with expert verified solutions from united states history modern america 1st edition you ll learn how to solve your
toughest homework problems our resource for

modern american history edition guided answer key pdf pdf - Jan 27 2022

web nov 9 2023 first published on fri 13 oct 2023 14 02 edt as with almost everything to do with this conflict it depends on
whom you ask some will begin with the romans others

handbook of clinical audiology seventh edition request pdf - Jan 30 2023

web aug 25 2014 request pdf handbook of clinical audiology seventh edition for more than 40 years katz s handbook of
clinical audiology has been the go to resource for graduate audiology students and

handbook of clinical audiology archive org - Oct 07 2023

web may 15 2020 for more than 40 years katz s handbook of clinical audiology has been the go to resource for graduate
audiology students and audiologists the text offers a clinical overview of current issues in and procedures in audiology all

handbook of clinical audiology jack katz google books - Feb 28 2023

web lippincott williams wilkins 2010 audiology 1056 pages for more than 35 years students and audiologists have turned to
the acclaimed handbook of clinical audiology to master the principles and methods of the field

handbook of clinical audiology google books - Jul 04 2023

web handbook of clinical audiology point lippincott williams wilkins editor jack katz contributor jack katz edition 6 illustrated publisher wolters kluwer health lippincott williams

[handbook of clinical audiology point lippincott williams wilkins](#) - Nov 27 2022

web jan 16 2009 find the best prices on handbook of clinical audiology point lippincott williams wilkins by katz at biblio hardcover 2009 lww 9780781781060

handbook of clinical audiology by katz jack good hardcover - Oct 27 2022

web feb 25 1998 title handbook of clinical audiology publisher lippincott williams wilkins baltimore md u s a publication date 2002 binding hardcover condition good edition 5th edition book type book

handbook of clinical audiology by jack katz open library - Aug 05 2023

web dec 26 2022 handbook of clinical audiology by jack katz 2009 lippincott williams wilkins edition in english 6th ed

handbook of clinical audiology google books - Jun 03 2023

web handbook of clinical audiology editors jack katz robert f burkard larry medwetsky edition illustrated publisher lippincott williams wilkins 2002 isbn 0683307657

handbook of clinical audiology google books - Apr 01 2023

web prepare your graduate students for their careers in audiology with katz s handbook of clinical audiology seventh edition this go to resource was developed by an unsurpassed team of editors and authors whose expertise in research and clinical practice spans all core areas of clinical audiology

handbook of clinical audiology point lippincott williams wilkins - May 22 2022

web 2 handbook of clinical audiology point lippincott williams wilkins 2022 04 03 are highlighted with boxes tables and figures which the reader can refer back to for quick revision above all the book enables medical students

handbook of clinical audiology point lippincott williams wilkins - Apr 20 2022

web thank you for reading handbook of clinical audiology point lippincott williams wilkins as you may know people have search numerous times for their chosen novels like this handbook of clinical audiology point lippincott williams wilkins but end up in harmful downloads rather than enjoying a good book with a cup of tea in the afternoon

başkent Üniversitesi bilgi paketi baskent edu tr - Jun 22 2022

web 2 jack katz larry medwetsky robert burkard and linda hood 2009 handbook of clinical audiology point lippincott williams wilkins 3 can koç 2013 kulak burun boğaz hastalıkları ve baş boyun cerrahisi 2 baskı güneş tıp kitabevi 4 fuat büyüklü 2013 kulak kulak burun boğaz ve baş boyun cerrahisi anadolu sanat

handbook of clinical audiology amazon com - Dec 29 2022

web jan 1 2009 for more than 35 years students and audiologists have turned to the acclaimed handbook of clinical

audiology to master the principles and methods of the field this text and reference offers scientific clinical and philosophical insights regarding current issues and procedures in audiology

handbook of clinical audiology point lippincott williams wilkins - Feb 16 2022

web costs its roughly what you infatuation currently this handbook of clinical audiology point lippincott williams wilkins as one of the most effective sellers here will unquestionably be in the course of the best options to review neuroscience for the study of communicative disorders subhash chandra bhatnagar 2002 this revised updated

handbook of clinical audiology seventh edition the point - Sep 06 2023

web about this title for more than 40 years jack katz s handbook of clinical audiology has been the go to resource for graduate audiology students and audiologists this edition s unsurpassed team of editors and authors whose expertise in both research and clinical practice spans all the core areas of clinical audiology ensures that the

handbook of clinical audiology point lippincott williams wilkins - Mar 20 2022

web handbook of clinical audiology lippincott williams wilkins rapid audiogram interpretation a clinician s manual provides a methodical step by step approach for interpreting audiograms

handbook of clinical audiology hardcover 2001 biblio - Sep 25 2022

web find the best prices on handbook of clinical audiology by katz phd jack at biblio hardcover 2001 lippincott williams wilkins 9780683307658

handbook of clinical audiology point lippincott williams wilkins - Aug 25 2022

web comprehensive handbook of pediatric audiology second edition is intended for use in doctoral level education programs in audiology or hearing science as well as to serve as an in depth

handbook of clinical audiology point lippincott williams wilkins - May 02 2023

web handbook of clinical audiology point lippincott williams wilkins read more detail

citation handbook of clinical audiology bibguru guides - Jul 24 2022

web handbook of clinical audiology 7th ed lippincott williams and wilkins 2014 other citation styles harvard turabian vancouver bibguru offers more than 8 000 citation styles including popular styles such as ama asa aapa cse ieee harvard turabian and vancouver as well as journal and university specific styles

centre number candidate number edexcel gcse mathematics a maths - Jun 03 2023

web 2013 pearson education ltd 6 7 4 p42059a0128 edexcel gcse mathematics a paper 2 calculator higher tier monday 4 march 2013 morning time 1 hour 45 minutes 1ma0 2h you must have ruler graduated in centimetres and millimetres protractor pair of compasses pen hb pencil eraser calculator tracing paper may be used instructions

pgsmaths edexcel march 2013 2h q01 stem and leaf - Feb 16 2022

web 13 8 9k views 9 years ago edexcel march 2013 2h model answer to an exam question by ph pgsmaths edexcel gcse mathematics a paper 2 calculator higher tier thursday 4 march

march 2013 edexcel maths calculator paper 2h pdf uniport edu - Apr 20 2022

web apr 2 2023 march 2013 edexcel maths calculator paper 2h 1 7 downloaded from uniport edu ng on april 2 2023 by guest march 2013 edexcel maths calculator paper 2h eventually you will totally discover a further experience and feat by spending more cash yet when pull off you endure that you require to acquire those all needs later having

mark scheme results summer 2013 pearson qualifications - Aug 05 2023

web aug 22 2013 paper 1ma0 2h question working answer mark notes 1 40 5 3 m1 for 1 5 6 or 1 5 1 5 m1 for adding area of 5 or 6 faces provided at least 3 are the correct area a1 cao nb anything that leads to a volume calculation 0 marks 2 not enough mincemeat since 600 700 or only able to make 38 mince pies since insufficient mincemeat 4

mark scheme results march 2013 pearson qualifications - Dec 29 2022

web apr 18 2013 march 2013 gcse mathematics linear 1ma0 higher non calculator paper 1h edexcel and btec qualifications edexcel and btec qualifications come from pearson the world s leading learning company we provide a wide range of qualifications including academic vocational

gcse maths edexcel november 2013 2h higher calculator complete paper - Jun 22 2022

web 0 00 1 29 34 gcse maths edexcel november 2013 2h higher calculator complete paper achieve maths 15 2k subscribers subscribe 306 share save 57k views 8 years ago all gcse maths videos

pgsmaths edexcel march 2013 2h q17 calculator youtube - Nov 27 2022

web model answer to an exam question by ph pgsmaths edexcel gcsemathematics apaper 2 calculator higher tierthursday 4 march 2013

maths genie edexcel gcse maths past papers mark - Apr 01 2023

web maths gcse past papers foundation and higher for the edexcel exam board with mark schemes grade boundaries model answers and video solutions

gcse edexcel maths a paper 2 calculator expert tuition - Jan 30 2023

web download past exam papers for gcse edexcel maths a paper 2 calculator to prepare for your exams gcse edexcel maths a paper 2 calculator past papers are available to download for free from various exam boards and school boards including aqa edexcel ocr and eduqas wjec

march 2013 edexcel maths calculator paper 2h download only - May 22 2022

web we allow march 2013 edexcel maths calculator paper 2h and numerous book collections from fictions to scientific research in any way accompanied by them is this march 2013 edexcel maths calculator paper 2h that can be your partner

march 2013 edexcel maths calculator paper 2h 2021 09 14 mcmahon richardson

mark scheme results november 2013 pearson qualifications - Oct 27 2022

web jan 9 2014 higher calculator paper 2h edexcel and btec qualifications edexcel and btec qualifications are awarded by pearson the uk s largest awarding body we provide a wide range of qualifications including academic vocational occupational and specific programmes for employers

mark scheme results march 2013 physics maths tutor - Jul 24 2022

web mark scheme results march 2013 gcse mathematics 2mb01 higher 5mb2h non calculator paper 01 edexcel and btec qualifications edexcel and btec qualifications come from pearson the world s leading learning company we provide a wide range of qualifications including academic vocational occupational and specific programmes for

mark scheme results march 2013 pearson qualifications - Oct 07 2023

web apr 18 2013 march 2013 gcse mathematics linear 1ma0 higher calculator paper 2h edexcel and btec qualifications edexcel and btec qualifications come from pearson the world s leading learning company we provide a wide range of qualifications including academic vocational occupational and specific programmes for employers

paper 2h march 2013 mark scheme pdf fraction mathematics scribd - May 02 2023

web gcse mathematics linear 1ma0 higher calculator paper 2h mark scheme edexcel and btec qualifications come from pearson the world s leading learning company if you have any subject specific questions about this specification you can speak directly to the subject team at pearson

edexcel gcse maths past papers edexcel mark schemes - Feb 28 2023

web find all edexcel gcse maths past papers and mark schemes for the new specification graded 9 1 revise better with maths made easy gcse mathematics paper 3 calculator foundation question paper mark scheme june 2013 paper 1 mar 2013 paper 1 question paper mark scheme model solution

q22 paper 2h march 2013 maths website - Aug 25 2022

web q22 paper 2h march 2013 share this video with your friends 1h march 2013 q3 paper 1h nov 2013 q4 paper 2h nov 2013 q24 paper 2h nov 2013 q8 paper 1h nov 2013 q10 paper 1h nov 2013 edexcel higher p1 june 2013 q17 q7 paper 1h june 2014 q4 paper 2h june 2014 q9 paper 2h june 2014 q24 paper 2h june 2014 edexcel higher p2

examiners report march 2013 gcse mathematics 1ma0 higher calculator - Jul 04 2023

web apr 18 2013 march 2013 gcse mathematics 1ma0 higher calculator paper 2 2 gcse mathematics 1ma0 2h edexcel and btec qualifications edexcel and btec qualifications come from pearson the world s leading learning a common mistake was to calculate 7 11 20 and stop there

mark scheme results march 2013 pmt - Mar 20 2022

web march 2013 gcse mathematics linear 1ma0 higher calculator paper 2h pmt edexcel and btec qualifications edexcel and btec qualifications come from pearson the world s leading learning company we provide a wide range of qualifications including academic vocational

[march 2013 edexcel maths calculator paper 2h pdf](#) - Sep 25 2022

web march 2013 edexcel maths calculator paper 2h edexcel a level further mathematics statistics jul 01 2022 build your students confidence in applying mathematical techniques to solving problems with resources developed with leading assessment consultant keith pledger and mathematics in education and industry mei

edexcel gcse maths past papers revision maths - Sep 06 2023

web paper 2 calculator 1ma0 2h higher download paper download mark scheme june 2013 mathematics a paper 1 non calculator 1ma0 1f foundation download paper download mark scheme paper 1 non calculator 1ma0 1h higher download paper download mark scheme paper 2 calculator 1ma0 2f foundation download paper